

Compton polarimetry for SuperKEKB: laser system, photon detector

D. Charlet¹, T. Ishibashi², A. Martens¹, M. Masuzawa², F.
Mawas^{1*}, Y. Peinaud¹, D. Zhou², F. Zomer¹

1: IJCLab; 2: KEK; *: PhD student

Compton scattering

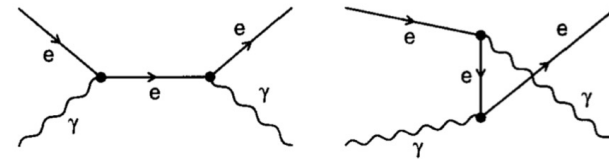

Fig. 1. Tree diagrams for $e^- \gamma \rightarrow e^- \gamma$

$$x = \frac{2E_0\omega_0}{m^2} (1 + \cos \alpha) \quad y = \frac{E_\gamma}{E_0}$$

The Compton cross-section averaged over scattered particles spins:

Differential cross-section

Transverse laser polarisation: nuisance parameter to minimize and keep under control

Transverse electron beam polarisation: intervenes as an asymmetry in the transverse plane

$$\frac{d\sigma}{dyd\varphi_{obs}}(x, y) = \frac{d\sigma_0}{dy}(x, y) + \frac{d\sigma_L}{dy}(x, y) \cos(2(\varphi_{obs} - \varphi_{las})) \mathcal{P}_L^{las} + \frac{d\sigma_{\parallel}}{dy}(x, y) \mathcal{P}_C^{las} (P_T f_T(x, y) \cos(\varphi_{obs} - \varphi_{elec}) + P_Z f_Z(x, y))$$

Electron beam polarization independent

Electron beam polarization dependent

$$\frac{d\sigma}{dy}(x, y) \cong \frac{d\sigma_0}{dy} (1 + \mathcal{P}_Z \mathcal{P}_C^{las} A_{LR})$$

⚠ But small opening angle of scattered particles:

- Transverse polarimetry is more difficult to implement wrt longitudinal polarimetry

Integration

1. For spin rotators at current B2E location of SuperKEKB
 - a nice place before BLA2LE where polarization is longitudinal and enough free space
 - polarimeter data is representative of polarization at Belle II IP (up to magnet misalignments)
2. For spin rotators at about 80m from Belle II IP
 - no solution found to measure longitudinal polarization
 - use same location but measure transverse polarization (no detailed study at this stage of this)

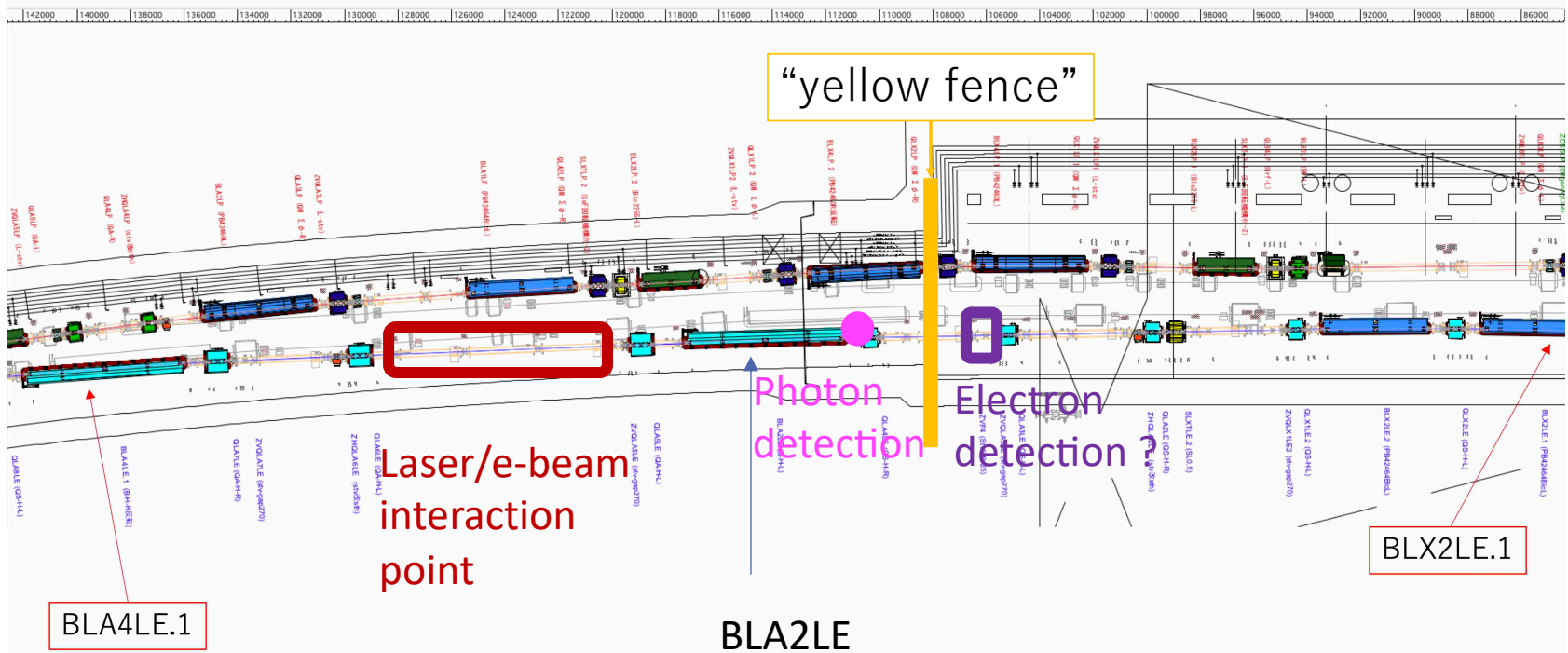

Mechanical system integration

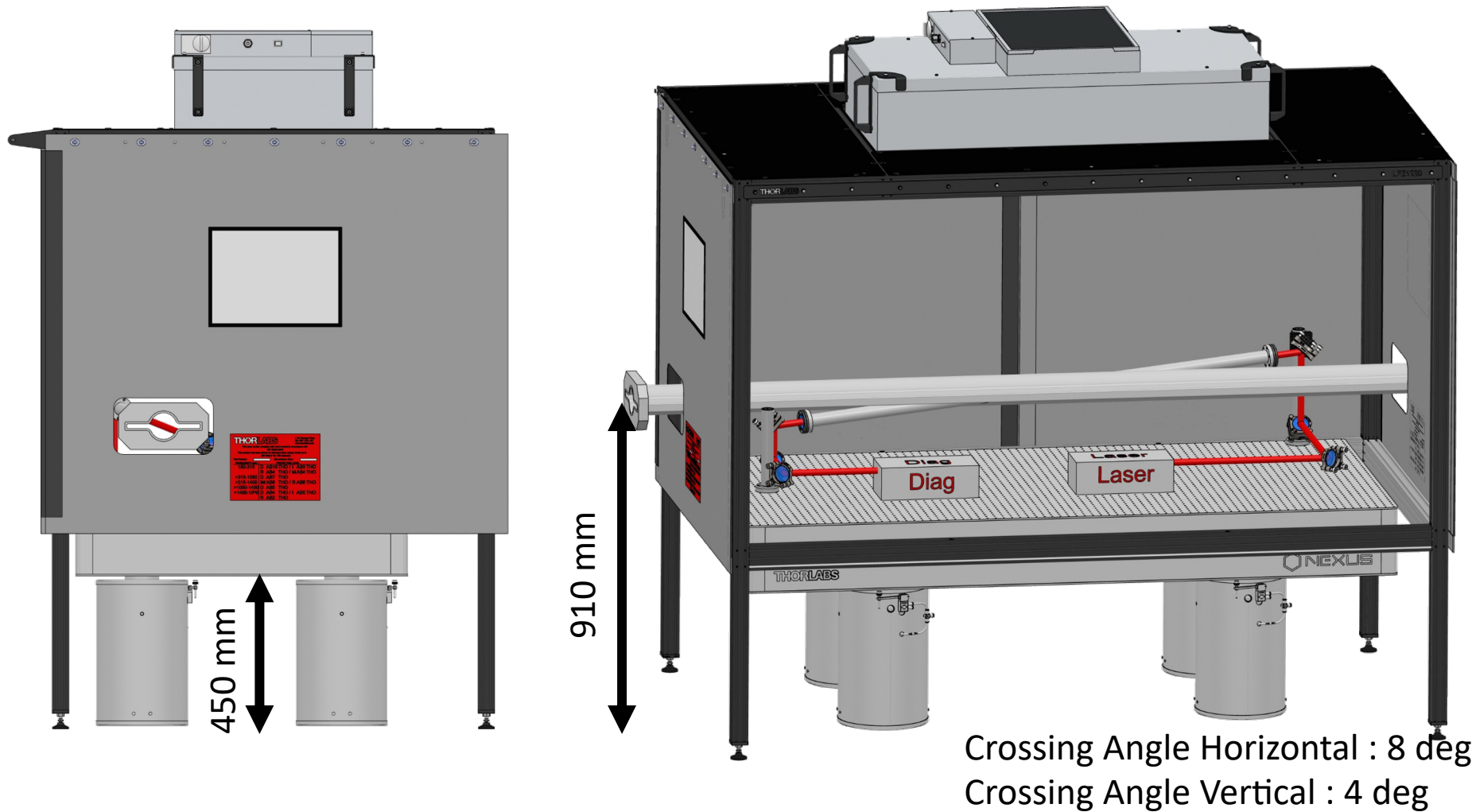

- + some neutron + lead shielding around electronics to be located below the table
- + some lead shielding around the table to protect the laser

Beam impedance (longitudinal)

Preliminary results of impedance calculation

- Impedance calculation by T. Ishibashi

- Longitudinal wake with 6 mm Gaussian bunch is very weak.
- The calculated loss factor, resistance and inductance are $4.4\text{e-}5$ V/pC, $3.1\text{e-}3$ Ohm, and $8.0\text{e-}4$ nH, respectively.
- Comparing with Table 1 of Ref. [1], these values are very small.

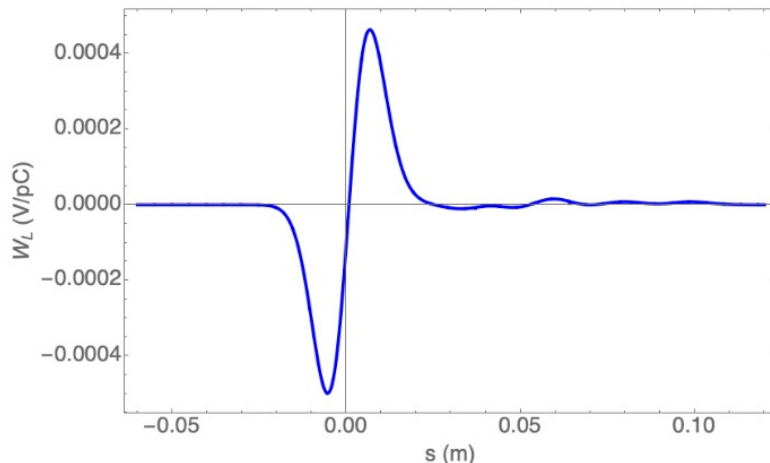

Table 1: Impedance budget for the SuperKEKB main rings. Summarised are the contributions to the loss factor $k_{||}$ [V/pC], the fitted resistance R [Ω] and inductance L [nH] for each type of components. The resistances and inductances are calculated at the nominal bunch lengths of $\sigma_z=5$ and 4.9 mm for LER and HER, respectively.

Component	LER			HER		
	$k_{ }$	R	L	$k_{ }$	R	L
ARES cavity	8.9	524	-	3.3	190	-
SC cavity	-	-	-	7.8	454	-
Collimator	1.1	62.4	13.0	5.3	309	10.8
Res. wall	3.9	231	5.7	5.9	340	8.2
Bellows	2.7	159	5.1	4.6	265	16.0
Flange	0.2	13.7	4.1	0.6	34.1	19.3
Pump. port	0.0	0.0	0.0	0.6	34.1	6.6
SR mask	0.0	0.0	0.0	0.4	21.4	0.7
IR duct	0.0	2.2	0.5	0.0	2.2	0.5
BPM	0.1	8.2	0.6	0.0	0.0	0.0
FB kicker	0.4	26.3	0.0	0.5	26.2	0.0
FB BPM	0.0	1.1	0.0	0.0	1.1	0.0
Long. kicker	1.8	105	1.2	-	-	-
Groove pipe	0.1	3.8	0.5	-	-	-
Electrode	0.0	0.7	5.7	-	-	-
Total	19.2	1137	36.4	29.0	1677	62.1

[1] D. Zhou et al., Impedance calculation and simulation of microwave instability for the main rings of SuperKEKB, in Proceedings of IPAC'14, Dresden, Germany.

Beam impedance (vertical)

Preliminary results of impedance calculation

- Impedance calculation by T. Ishibashi
 - Vertical dipole and quadrupole wakes with 6 mm Gaussian bunch are weak.
 - The dipole and quadrupole kick factors weighted by beta function $\beta_y=100$ m are $\beta_y\kappa_y=-0.89$ V/pC and -0.88 V/pC, respectively. These values are very small, concerning the total $\beta_y\kappa_y$ of HER in the order of 10^4 V/pC.

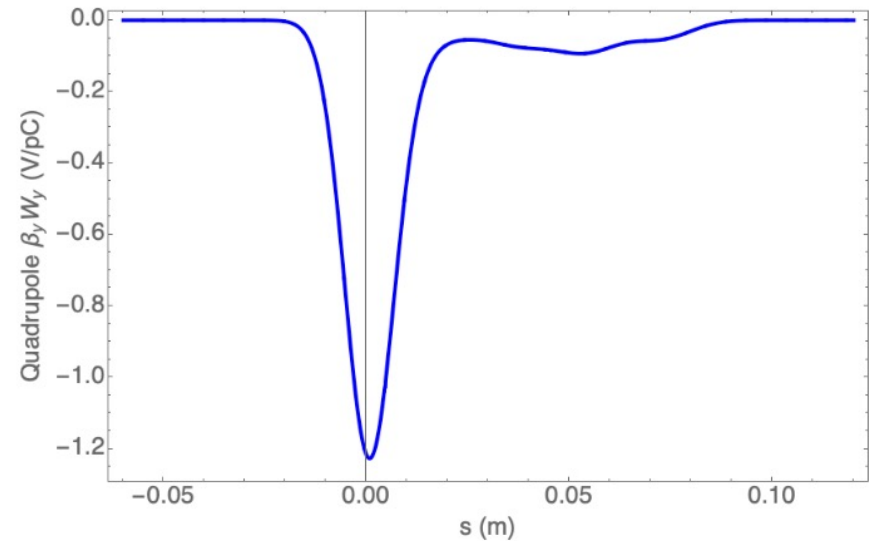
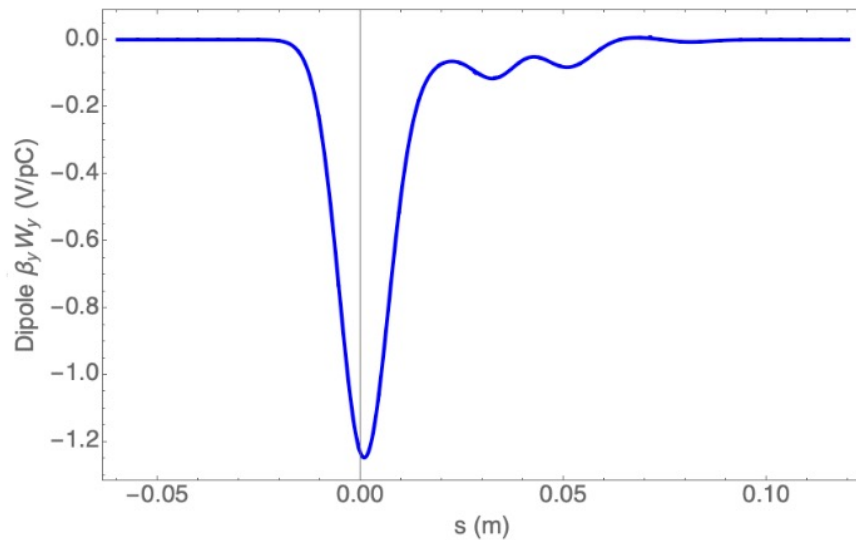

Laser system

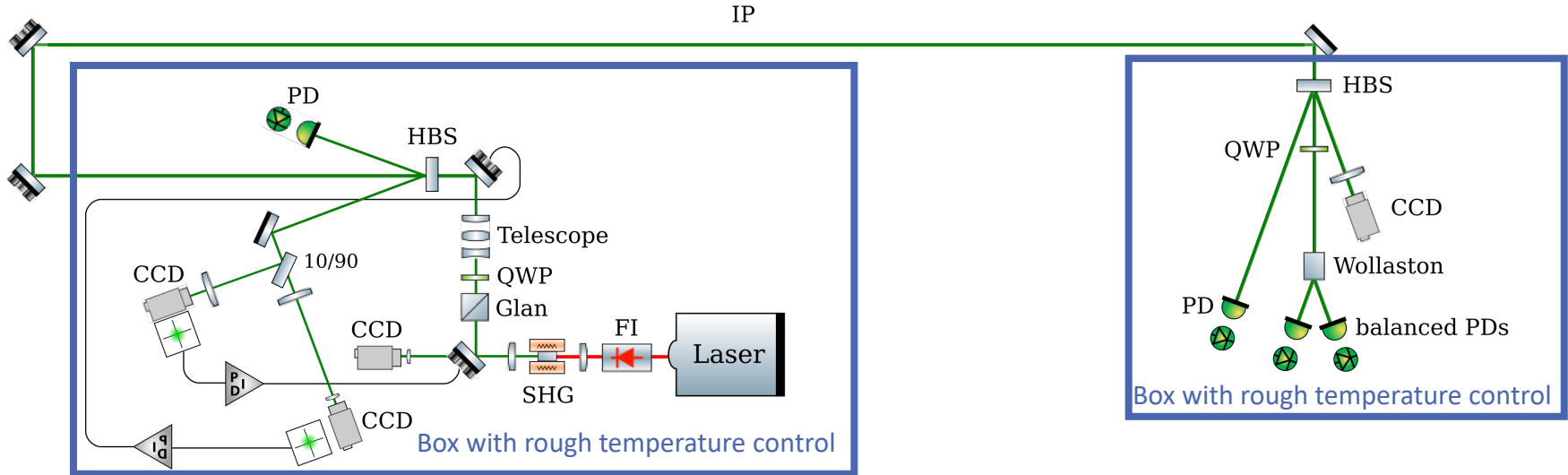

Rough design based on past experience

300 μ m beam size shall not be a problem (Rayleigh range of 1m)

Elliptic beam can be delivered with cylindrical lenses/mirrors

Key aspect: remote operation of the system that will be located in the tunnel

Possibility to synchronize the laser on the RF clock of the accelerator using the WhiteRabbit+IDROGEN technology under experimental investigation at IJCLab

Photon detector integration

'minor' modifications of BLA2LE region

- no modification of magnet required
- NEG pumping on the 'wrong' side

Requires modification of a pipe to let photon beam out

- proposed pipe modification (validated by T. Ishibashi and D. Zhou)

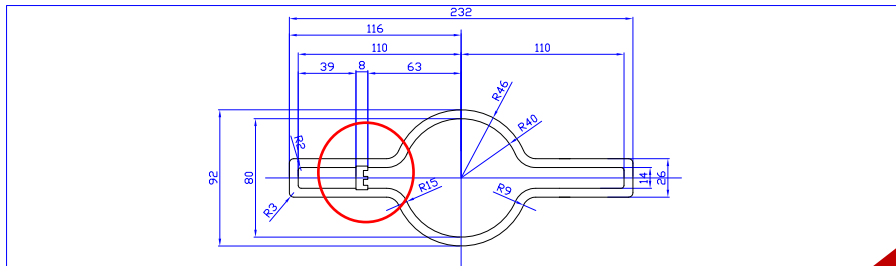

Pumping port side need to be changed.

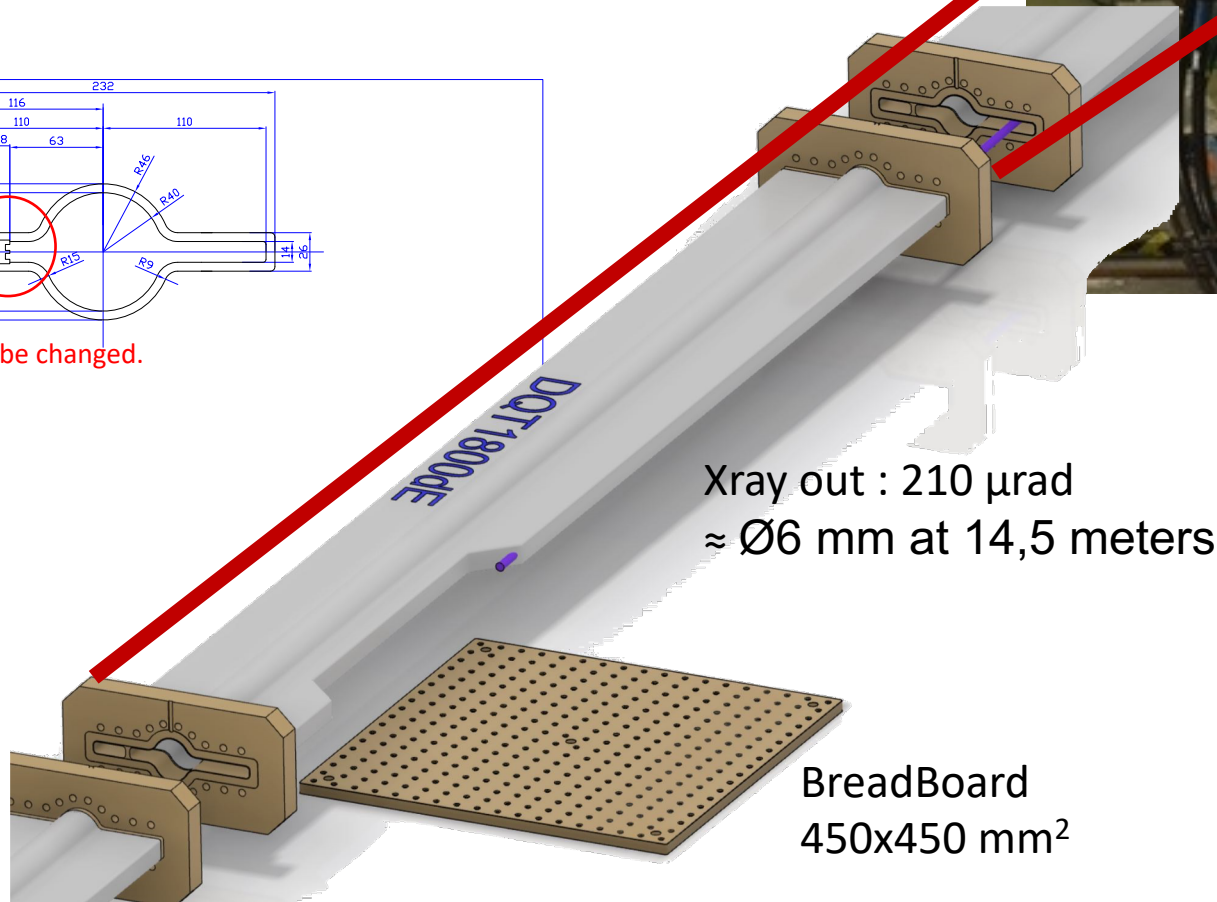

Xray out : 210 μ rad
 $\approx \text{Ø}6$ mm at 14,5 meters

BreadBoard
450x450 mm²

Integration in accelerator

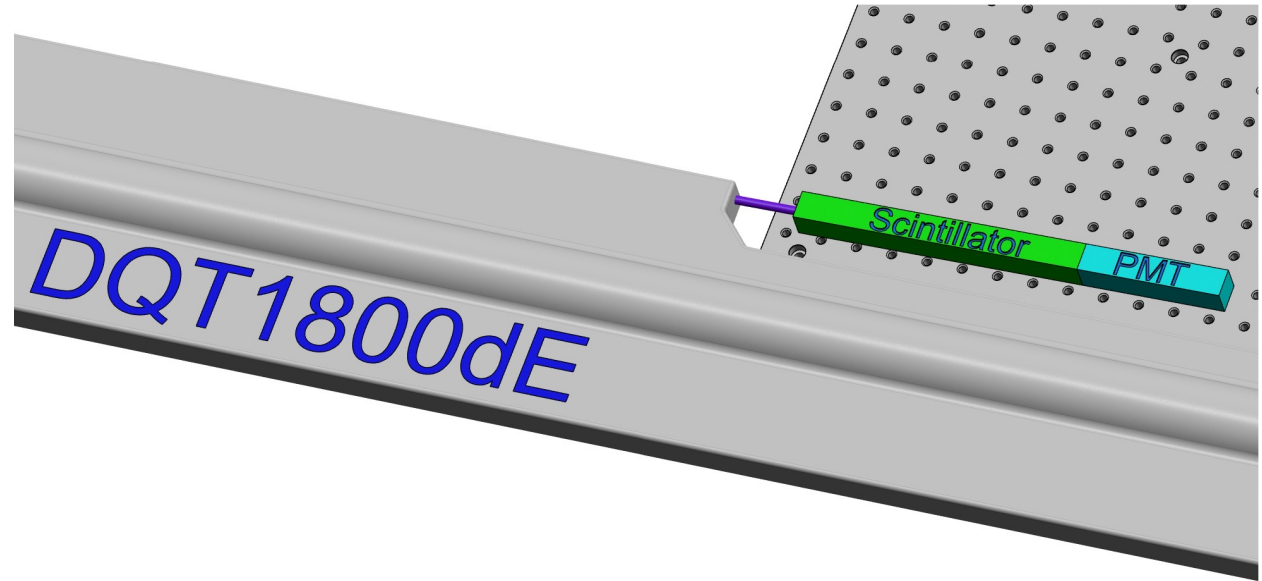
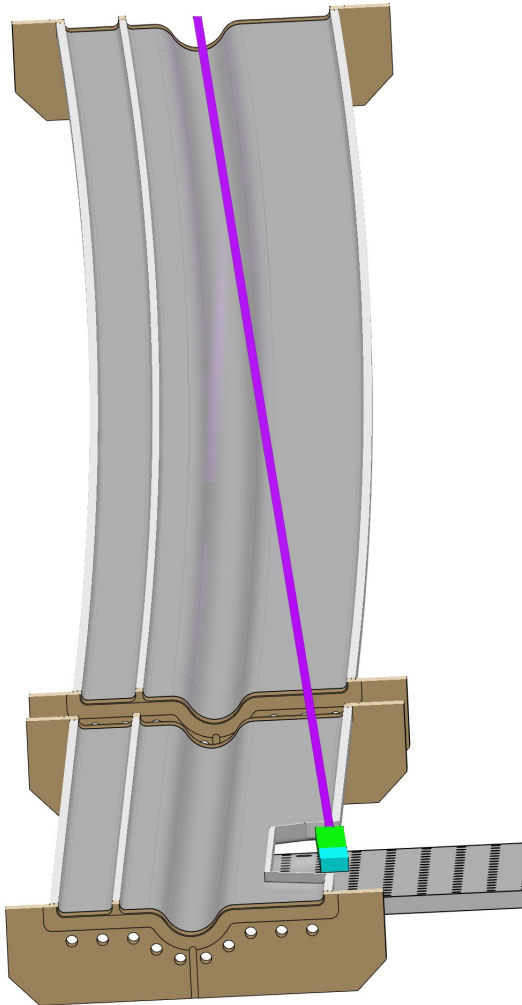

Beam pipe at $\sim 1\text{m}$ from ground
Electronics can be located and shielded on ground below
scintillator +PMT

Single channel photon detector

Basic elements

- a VERY FAST radhard scintillating crystal \rightarrow BaF₂
 - Need to filter out the slow component \rightarrow UV optical filters
- a PMT with low transit time dispersion \rightarrow commercially available (hamamatsu for instance)
- Bunch/bunch measurement

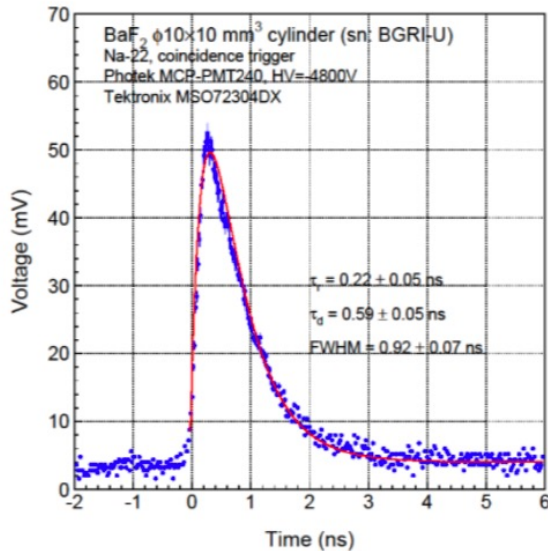

Energy measurement

2500 histograms

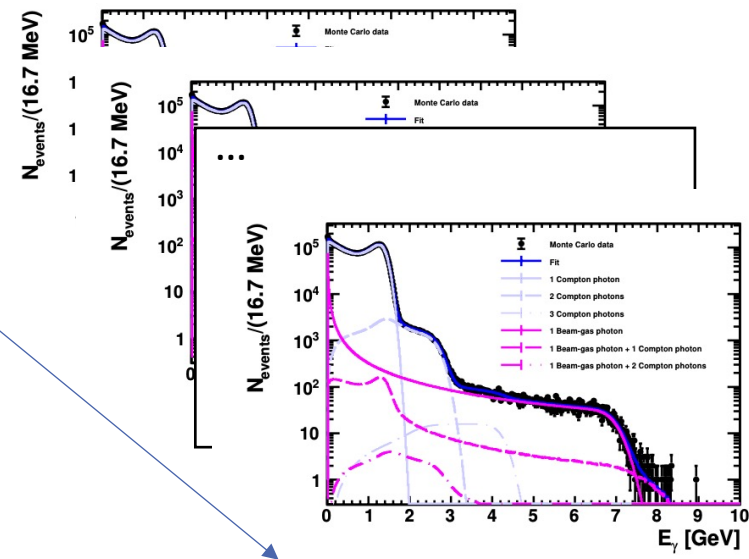

Funding request to ANR submitted (answer feb-June '24)

Conceptual acquisition chain

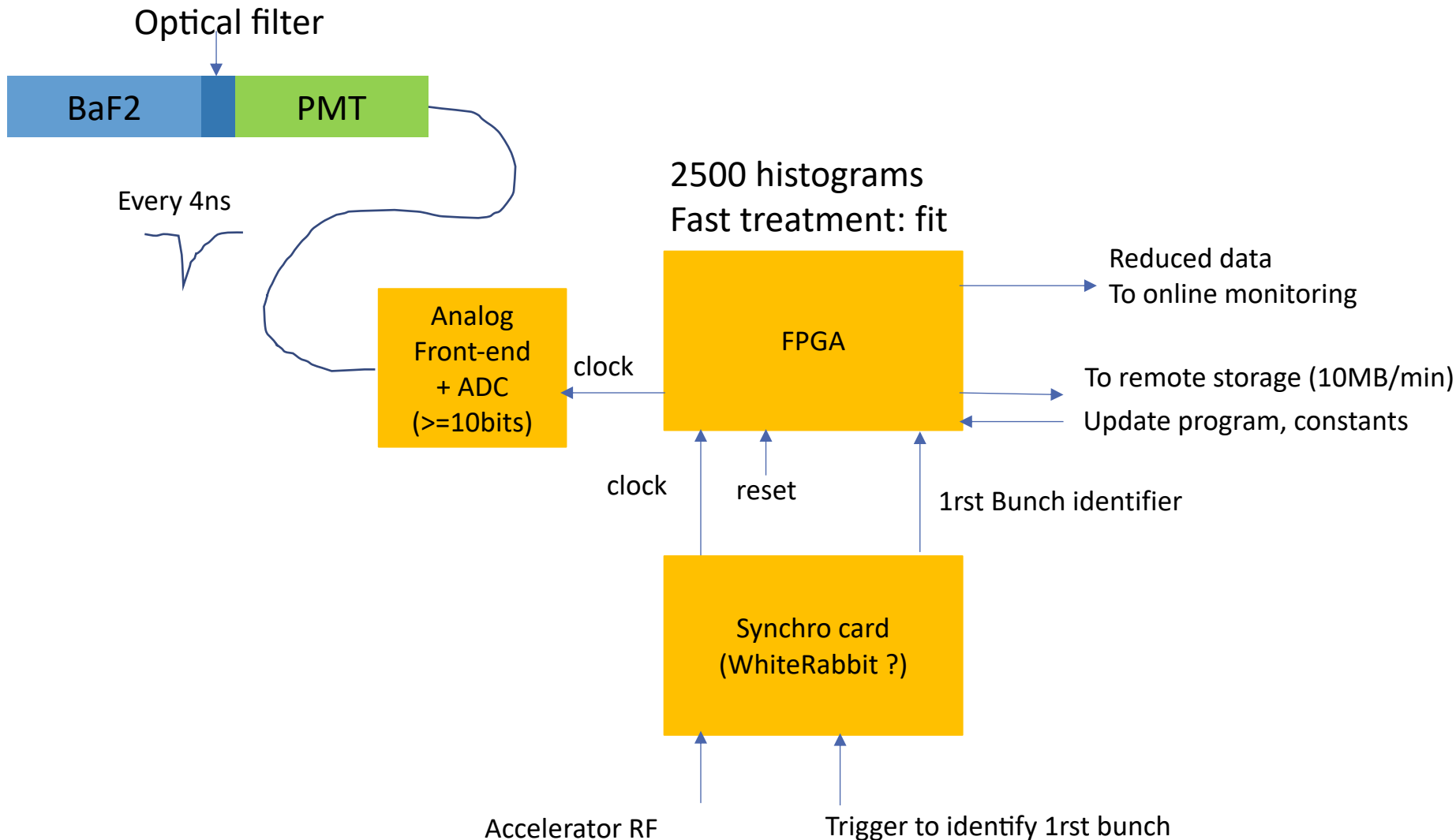

Expected performance

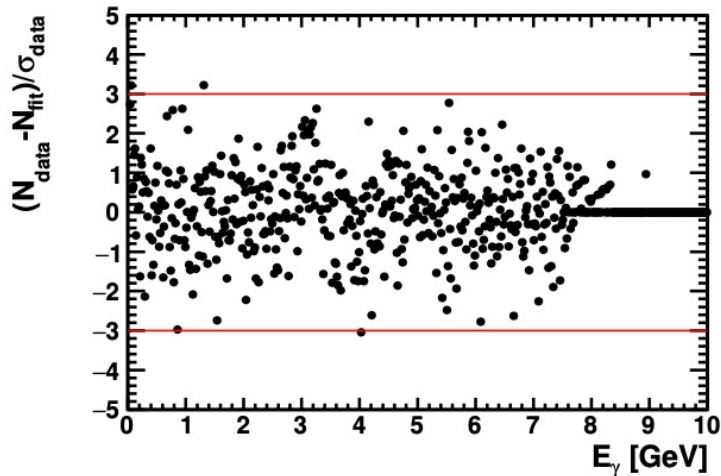
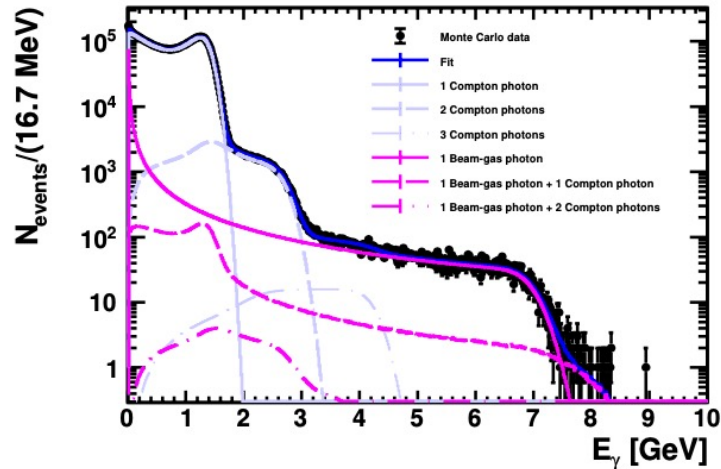

Table 4. Systematic uncertainties on the extraction of P_z , see text for details. Background modeling and absolute knowledge of the laser polarization dominates.

Source	Uncertainty on P_z (%)
Laser beam polarization	0.30
Backgrounds	0.16
Fit procedure	0.080
Beam energy	0.050
Spatial misalignment	0.015
Angular misalignment	0.015
Longitudinal misalignment	0.015
Transverse electron beam polarization	0.015
Total	0.35

- Statistical precision: 1%/bunch every 5min
- NB: fit can be performed in 1min for the 2500 bunches assuming few nuisance parameters known and fixed (calibration can occur from time to time)
- Systematic uncertainty related to **beam transport** from Compton IP to Belle 2 IP need to be evaluated → misalignments in beam transport

Conclusion & Prospects

- A summary of the conceptual studies performed for the laser system and the scattered photon detector has been published recently in JINST
- A summary of this paper is inserted in the current CDR draft
- Further progress on detector relies on success of funding
- Synchronisation scheme for laser to be validated in 2024
- Currently investigating possibility of a concept of a transverse polarimeter using converter + pixels

Conceptual study of a Compton polarimeter for the upgrade of the SuperKEKB collider with a polarized electron beam

D. Charlet,^a T. Ishibashi,^b A. Martens,^{a,*} M. Masuzawa,^b F. Mawas,^a Y. Peinaud,^a D. Zhou^b and F. Zomer^a

^aUniversité Paris-Saclay, CNRS/IN2P3, IJCLab, 91405 Orsay, France

^bHigh Energy Accelerator Research Organization (KEK), Tsukuba 305-0801, Japan

E-mail: aurelien.martens@ijclab.in2p3.fr

ABSTRACT: The physics scope of the Belle II experiment currently acquiring data at the SuperKEKB collider will expand with a polarized electron beam upgrade, as recently proposed. Among the required elements for this upgrade, a real time diagnosis of the polarization is necessary to ensure it is large for all bunches in the accelerator during its regular operation. This will be realized by inserting a Compton polarimeter in the accelerator. Its conceptual design is described and no show-stopper for its integration has been identified. An estimation of the sensitivity of the polarimeter is made by means of toy Monte-Carlo studies. The proposed design accounts for the constraint to preserve the performance of the SuperKEKB accelerator and to cope with the short time separation of successive bunches. We show that the polarimeter will measure for each bunch the polarization within five minutes with a statistical precision below 1% and systematic uncertainties below 0.5%. It has the capability of providing this information online on a similar timescale. This work paves the way towards future implementation of real-time Compton polarimetry in several future projects.

KEYWORDS: Accelerator Subsystems and Technologies; Beam-line instrumentation (beam position and profile monitors, beam-intensity monitors, bunch length monitors); Instrumentation for particle accelerators and storage rings - high energy (linear accelerators, synchrotrons)

*Corresponding author.

$$\frac{d\sigma}{dy}(x, y) \cong \frac{d\sigma_0}{dy} (1 + \mathcal{P}_Z \mathcal{P}_C^{las} A_{LR})$$

$$\frac{d\sigma}{dy}(x, y) \cong \frac{d\sigma_0}{dy} (1 + \mathcal{P}_T \mathcal{P}_C^{las} A_{UD})$$

Compton polarimetry

Polarization dependent term generates a left-right asymmetry function of E_γ

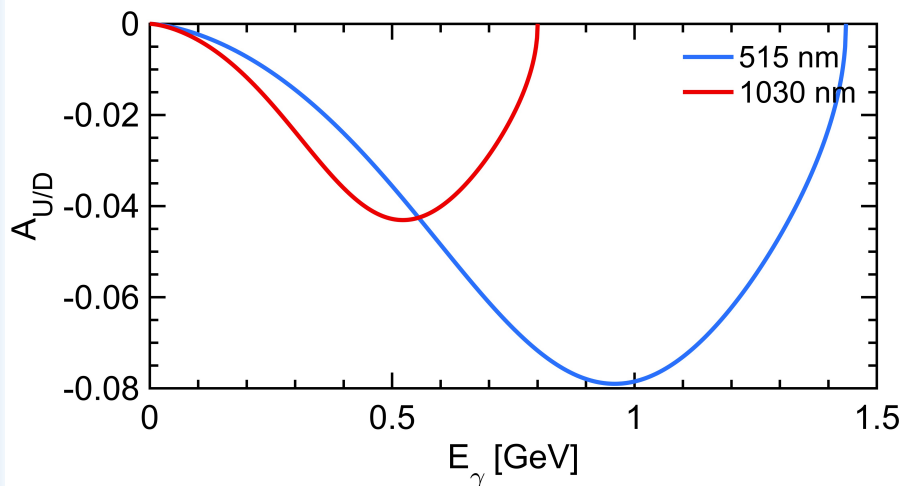
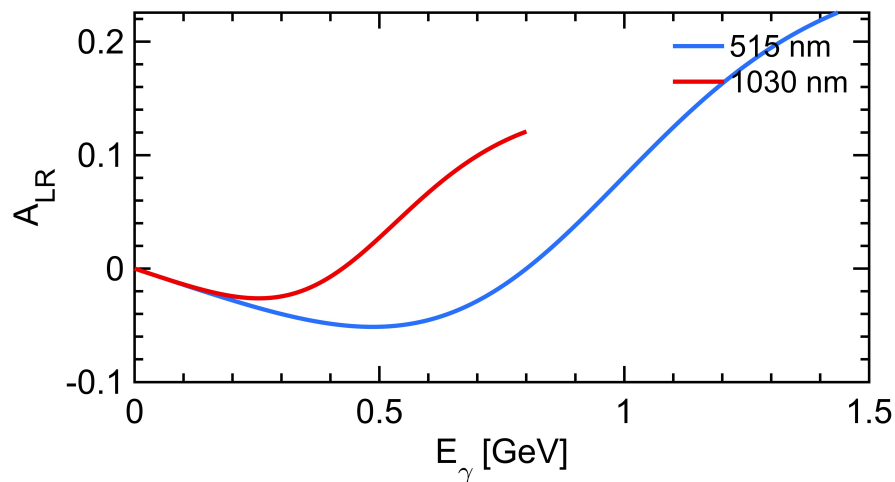
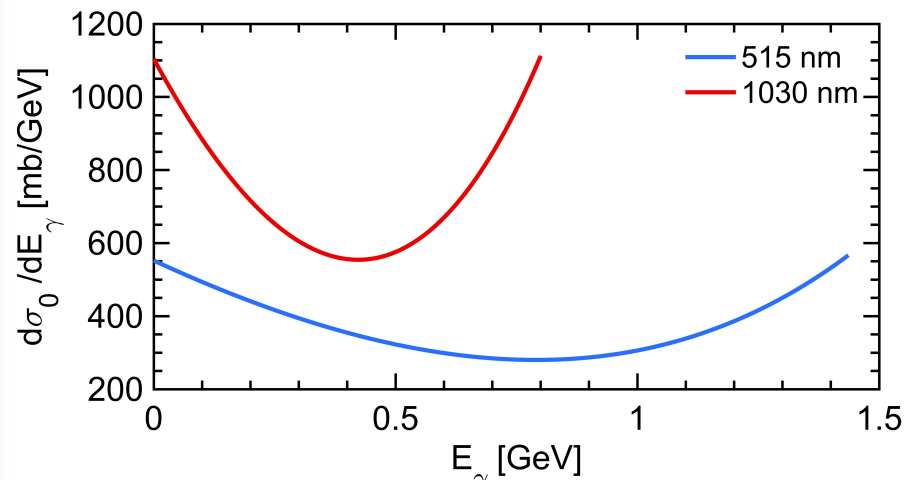

Use green (~515nm) laser
Postpone transverse polarimetry to a later stage

Conceptual design

- A summary of the conceptual studies performed for the laser system and the scattered photon detector has been published recently
- A summary of the results is inserted in the current CDR draft

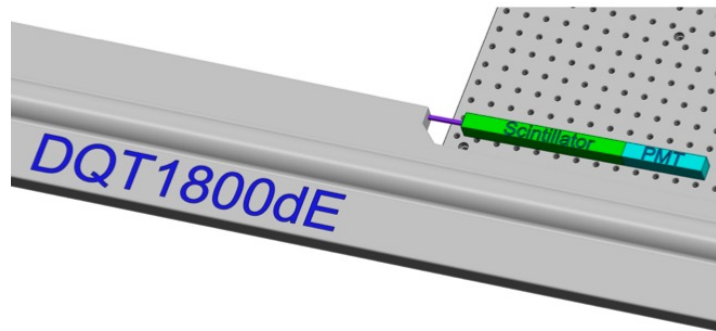

Figure 4. Drawing of the modified beam pipe for the insertion of the photon calorimeter in the SuperKEKB ring.

Conceptual study of a Compton polarimeter for the upgrade of the SuperKEKB collider with a polarized electron beam

D. Charlet,^a T. Ishibashi,^b A. Martens,^{a,*} M. Masuzawa,^b F. Mawas,^a Y. Peinaud,^a D. Zhou^b and F. Zomer^a

^aUniversité Paris-Saclay, CNRS/IN2P3, IJCLab, 91405 Orsay, France

^bHigh Energy Accelerator Research Organization (KEK), Tsukuba 305-0801, Japan

E-mail: aurelien.martens@ijclab.in2p3.fr

ABSTRACT: The physics scope of the Belle II experiment currently acquiring data at the SuperKEKB collider will expand with a polarized electron beam upgrade, as recently proposed. Among the required elements for this upgrade, a real time diagnosis of the polarization is necessary to ensure it is large for all bunches in the accelerator during its regular operation. This will be realized by inserting a Compton polarimeter in the accelerator. Its conceptual design is described and no show-stopper for its integration has been identified. An estimation of the sensitivity of the polarimeter is made by means of toy Monte-Carlo studies. The proposed design accounts for the constraint to preserve the performance of the SuperKEKB accelerator and to cope with the short time separation of successive bunches. We show that the polarimeter will measure for each bunch the polarization within five minutes with a statistical precision below 1% and systematic uncertainties below 0.5%. It has the capability of providing this information online on a similar timescale. This work paves the way towards future implementation of real-time Compton polarimetry in several future projects.

KEYWORDS: Accelerator Subsystems and Technologies; Beam-line instrumentation (beam position and profile monitors, beam-intensity monitors, bunch length monitors); Instrumentation for particle accelerators and storage rings - high energy (linear accelerators, synchrotrons)

*Corresponding author.

Beam sizes and spin projection in z

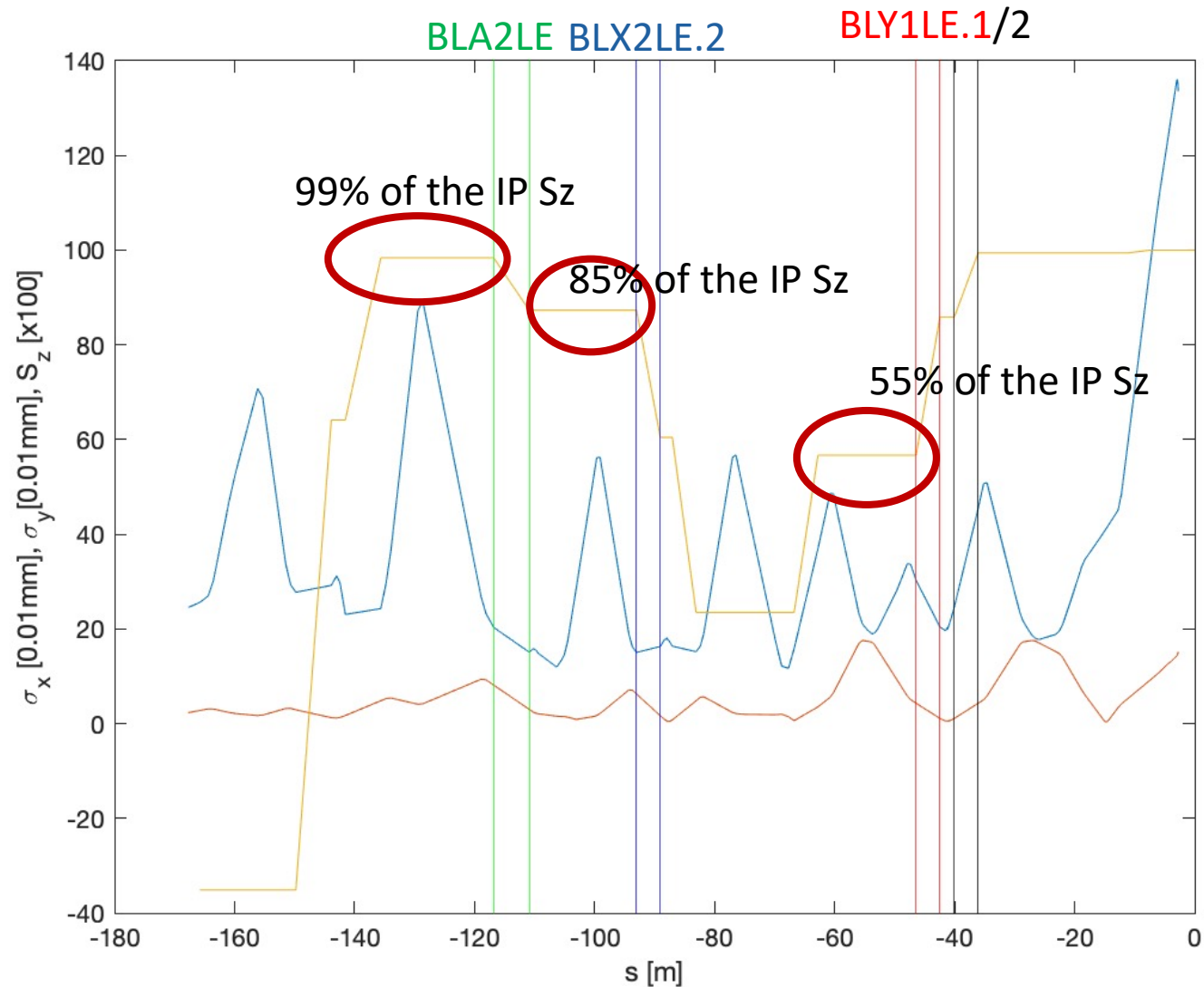

Transverse polarimetry at HERA

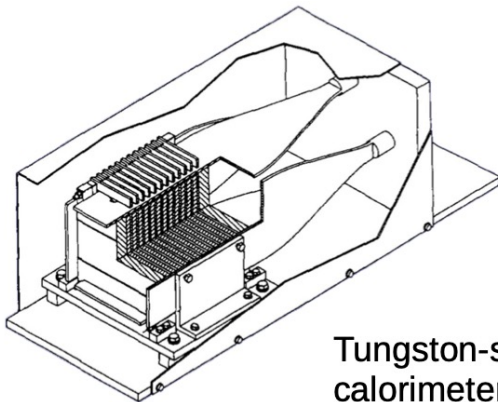

Tungsten-scintillator sampling calorimeter $12 \times 1.6 X_0$
Two optically isolated halves,
read-out on four sides

$$E = E_{\text{up}} + E_{\text{down}}$$
$$\eta = \frac{E_{\text{up}} - E_{\text{down}}}{E_{\text{up}} + E_{\text{down}}}$$

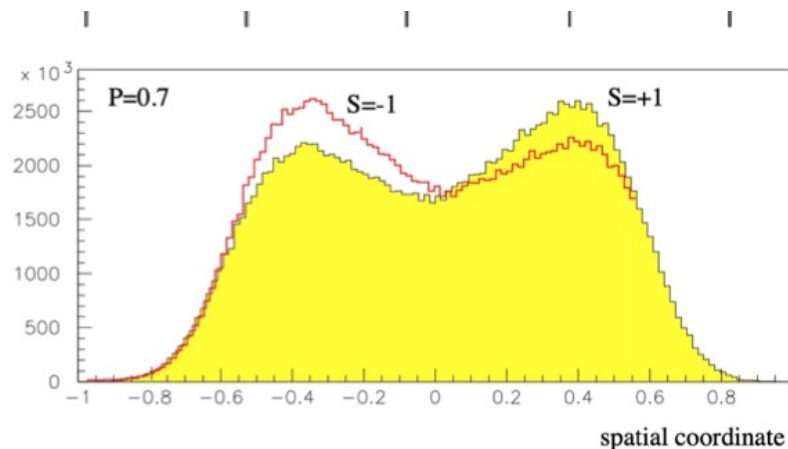

Exactly the operation that was done at HERA
TPOL a long time ago.

Notoriously a difficult task but 'do-able'

- Requires detailed simulations
- Requires some transverse sampling (not easy for photons)

Eased by implementing a nicely vertically segmented electron detector.

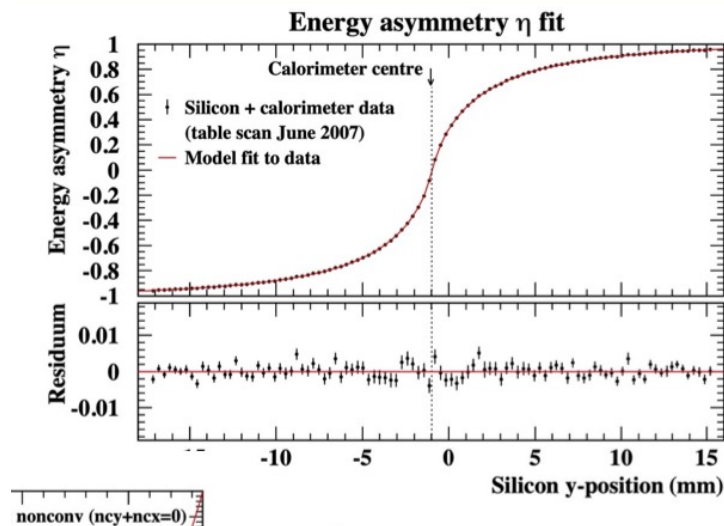

Choice of scintillating material

Basic elements

- a VERY FAST radhard scintillating crystal → BaF₂, the only solution ?
- Filter for the slow component
- a PMT with low transit time dispersion (AND solar blind ?) → commercially available ?
- Associated electronics

Table 35.4: Properties of several inorganic crystals. Most of the notation is defined in Sec. 6 of this *Review*.

Parameter:	ρ	MP	X_0^*	R_M^*	dE/dx^*	λ_I^*	τ_{decay}	λ_{max}	n^\dagger	Relative output [‡]	Hygroscopic?	$d(\text{LY})/dT$
Units:	g/cm ³	°C	cm	cm	MeV/cm	cm	ns	nm				%/°C [§]
NaI(Tl)	3.67	651	2.59	4.13	4.8	42.9	245	410	1.85	100	yes	-0.2
BGO	7.13	1050	1.12	2.23	9.0	22.8	300	480	2.15	21	no	-0.9
BaF₂	4.89	1280	2.03	3.10	6.5	30.7	650 ^s <0.6 ^f	300 ^s 220 ^f	1.50	36 ^s 4.1 ^f	no	-1.9 ^s 0.1 ^f
CsI(Tl)	4.51	621	1.86	3.57	5.6	39.3	1220	550	1.79	165	slight	0.4
CsI(Na)	4.51	621	1.86	3.57	5.6	39.3	690	420	1.84	88	yes	0.4
CsI(pure)	4.51	621	1.86	3.57	5.6	39.3	30 ^s 6 ^f	310	1.95	3.6 ^s 1.1 ^f	slight	-1.4
PbWO ₄	8.30	1123	0.89	2.00	10.1	20.7	30 ^s 10 ^f	425 ^s 420 ^f	2.20	0.3 ^s 0.077 ^f	no	-2.5
LSO(Ce)	7.40	2050	1.14	2.07	9.6	20.9	40	402	1.82	85	no	-0.2
PbF ₂	7.77	824	0.93	2.21	9.4	21.0	-	-	-	Cherenkov	no	-
CeF ₃	6.16	1460	1.70	2.41	8.42	23.2	30	340	1.62	7.3	no	0
LaBr ₃ (Ce)	5.29	783	1.88	2.85	6.90	30.4	20	356	1.9	180	yes	0.2
CeBr ₃	5.23	722	1.96	2.97	6.65	31.5	17	371	1.9	165	yes	-0.1

Slow component filtering

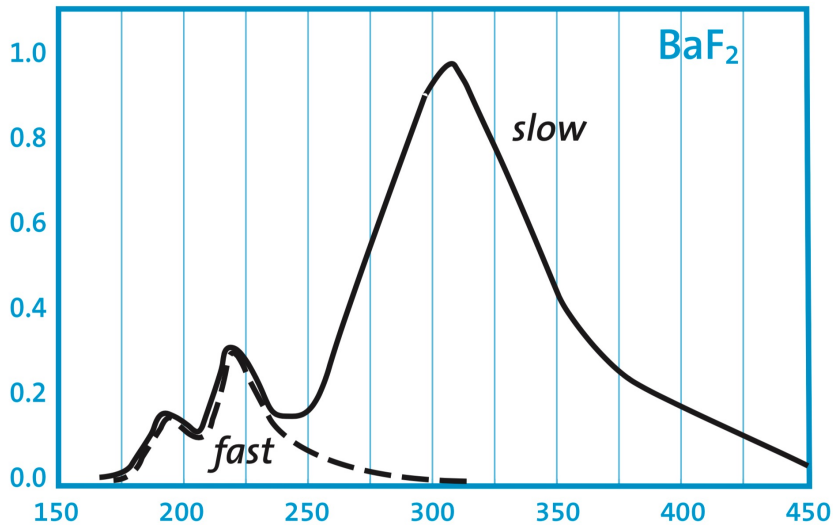

From Saint-Gobain datasheet.

Long tail → pile-up

Requires subtraction (in average), but fluctuations remain → spoil resolution

Solar blind photocathodes (CsTe) only reduce the. Slow component such that is amounts about 50% of the final light yield

Use UV optical filters instead → commercial products exist for instace at 185nm +- 20nm (FWHM)

Y doped BaF2 being investigated

Stefan Diehl *et al* 2015 *J. Phys.: Conf. Ser.* **587** 012044

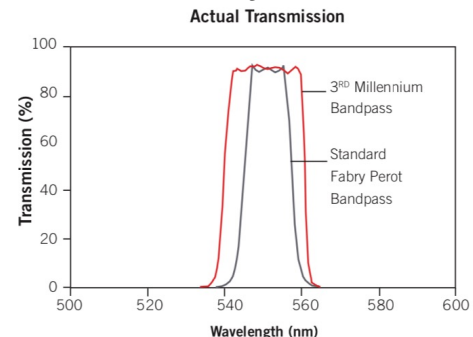

PMT

- Main requirements: fast (low rise time, low transfer time spread) and not blind to UV.

Figure 1: Typical spectral response

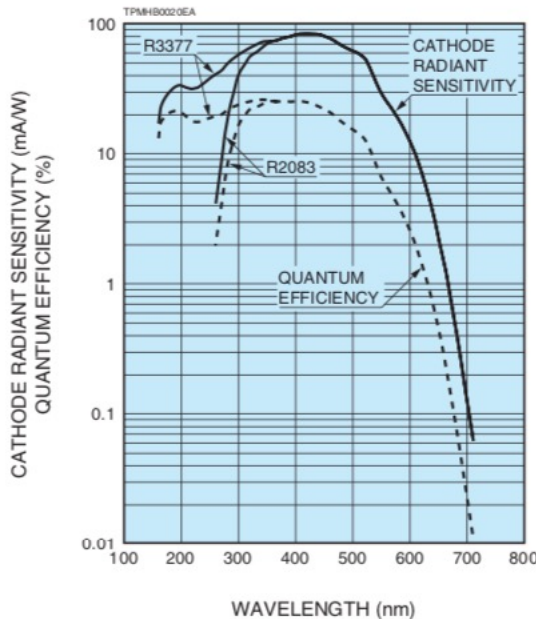

HAMAMATSU
PHOTON IS OUR BUSINESS

PHOTOMULTIPLIER TUBES
R2083, R3377

FEATURES

- High speed response
- Assembly type is also available
 - : H2431-50 (R2083 built-in type)
 - : H3378-50 (R3377 built-in type)

APPLICATIONS

- High energy physics
- Scintillation counting



SPECIFICATIONS

GENERAL

Parameter		Description / Value	Unit
Spectral response	R2083	300 to 650	nm
	R3377	160 to 650	nm
Wavelength of maximum response		420	nm
Photocathode	Material	Bialkali	—
	Minimum effective area	φ46	mm
Window material	R2083	Borosilicate glass	—
	R3377	Silica glass	—
Dynode	Structure	Linear focused	—
	Number of stages	8	—
Operating ambient temperature		-30 to +50	°C
Storage temperature		-30 to +50	°C
Base		19-pin glass base with SMA output connector	—
Suitable socket		E678-19J (supplied)	—

MAXIMUM RATINGS (Absolute maximum values)

Parameter		Value	Unit
Supply voltage	Between anode and cathode	3500	V
	Between anode and last dynode	1000	V
Average anode current		0.2	mA

CHARACTERISTICS (at 25 °C)

Parameter		Min.	Typ.	Max.	Unit
Cathode sensitivity	Luminous (2856 K)	60	80	—	μA/lm
	Blue sensitivity Index	R2083	10.0	—	—
Anode sensitivity	Luminous (2856 K)	50	200	—	A/lm
	Gain	—	2.5 × 10 ⁶	—	—
Anode dark current (after 30 min storage in darkness)		—	100	800	nA
Time response	Anode pulse rise time	—	0.8	—	ns
	Electron transit time	—	16	—	ns
	Transit time spread (FWHM)	—	0.37	—	ns
Pulse linearity at 2 % deviation		—	100	—	mA