



DRIVEN BY VISIONS
OF TOMORROW

MTU Aero Engines – Driven by visions of tomorrow

Belle II Industry Meeting - February 2024

1 Our
environment

2 Our
track record

3 Our
expertise

4 Your
questions

Agenda



1 Our environment

We shape the future of aviation!



A passenger aircraft is made up of up to

6 million components

~ **2 billion people**

out of 7.95 billion have flown in an aircraft to date

Fuel consumption per 100 passenger kilometers:

2.9 liters of kerosene

Nearly doubling the active fleet

to **48,000 aircraft** by 2040

The geared turbofan reduces

75% of the noise footprint

We shape the future of aviation!

What we do?

Design, development, production and support of aircraft engines in all thrust categories

Commercial business: 30% of aircraft have MTU technology on board

Military business: full system capability, for more than 80 years

Commercial MRO: worldwide leader in customized engine service solutions

MRO-Portfolio: 1.100+ Shop Visits p.a. for 30+ Engine types

Fiscal year 2022: Revenue around € 5.3 billion, EBIT adj. € 655 million

~ **tenfold*** increase in share value since 2005

* Basis: Stock price March 30 2023

How we do it

People: More than 11,000 engine experts at 17 locations

Partnerships: with all OEMs, airlines and the German Air Force (program shares from 5% up to 40%)

Technology: 300 technology projects, 2,675 patents and 700 inventors

Products: High-pressure compressor, low-pressure turbine, turbine center frame

Process: Lifetime Excellence (lifecycles from 25 to 50 years)

Culture: innovative and competent

€ **4 billion** invested in approx. 10 years

The Geared Turbofan Is Setting New Standards

Noise Footprint

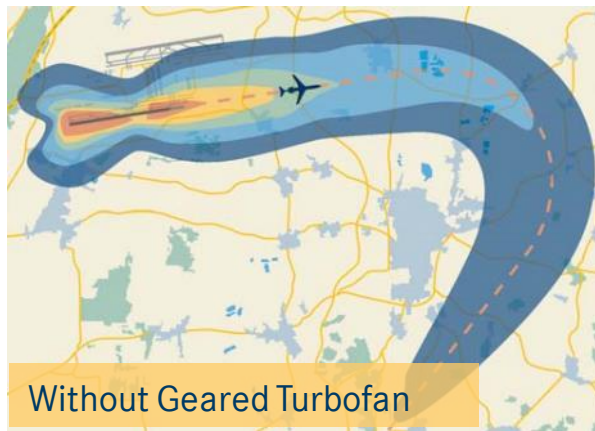

Munich International Airport (MUC)



Noise Simulation: Pratt & Whitney SEL Contour Source: Wyle Laboratories

MTU Contribution

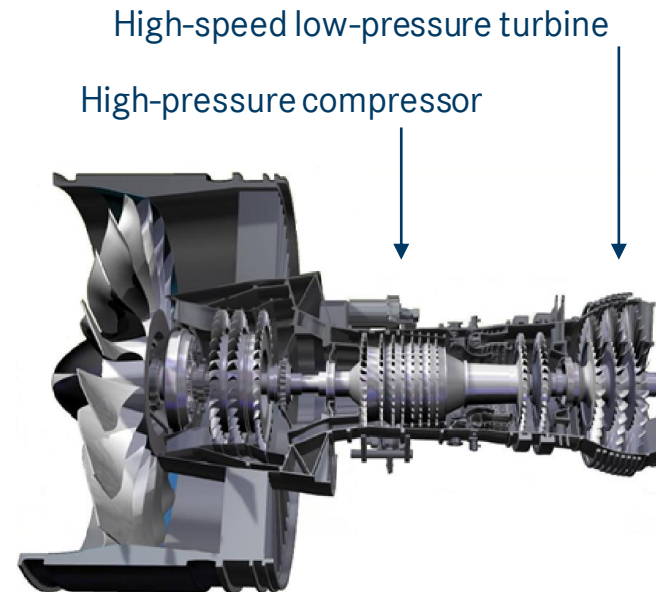

- Geared Turbofan reduces:
- Noise footprint by 75%
 - Fuel consumption and CO₂-emissions by 16%
 - NO_x-emissions by 50%

Chosen for three Airframes



MTU pursues a sustainable growth strategy in all of its business segments - based on stable and long-term customer relationships

Balanced portfolio



Leading technology

Benchmark competitiveness



Innovative culture



2 Our track record

Partners and customers appreciate MTU's excellence

MTU looks back on many important names from the German industrial history – from 1934 to date

1934

BMW Flugmotorenbau GmbH
is founded



1969

MTU
50% Daimler Benz
50% MAN



1965

MAN takes over
BMW Triebwerkbau



1989

MTU becomes an affiliate of
Deutsche Aerospace, later
renamed DaimlerChrysler
Aerospace (DASA)

2005

MTU goes public



Today

MTU Aero Engines is
admitted to the DAX,
Germany's primary stock
index



Focus on **military** applications

Focus on **commercial** applications

MTU is an essential partner in the engine value chain

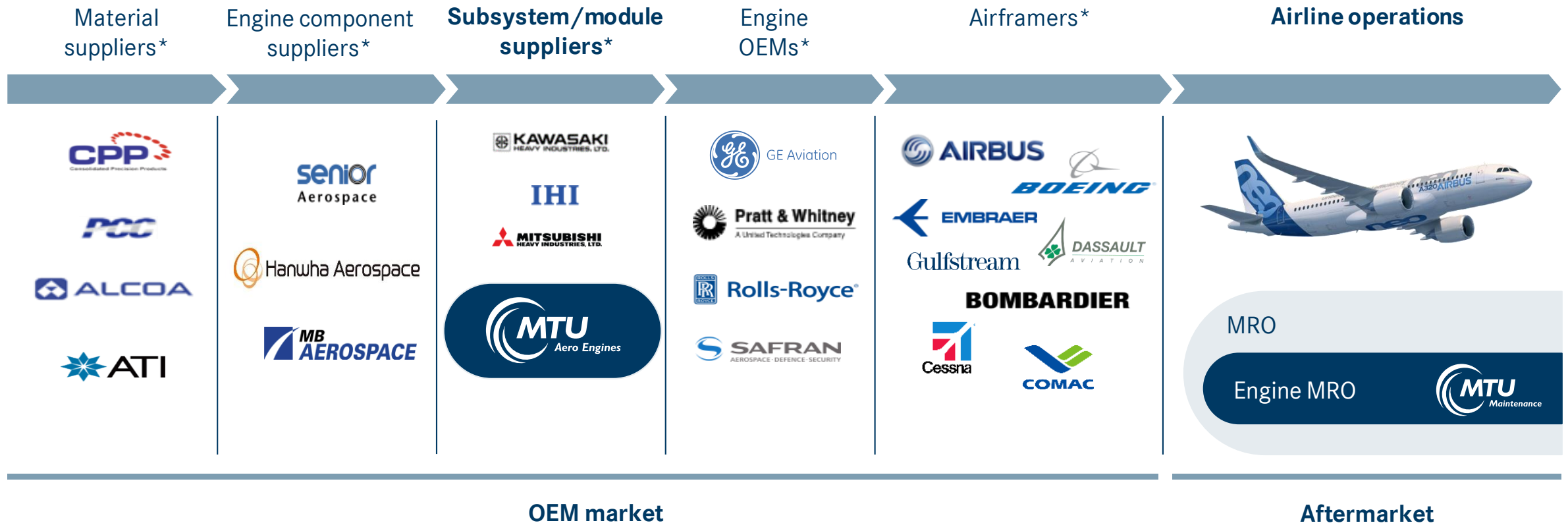

*selected market participants

A balanced portfolio and products in all thrust categories ensure MTU's long-term success

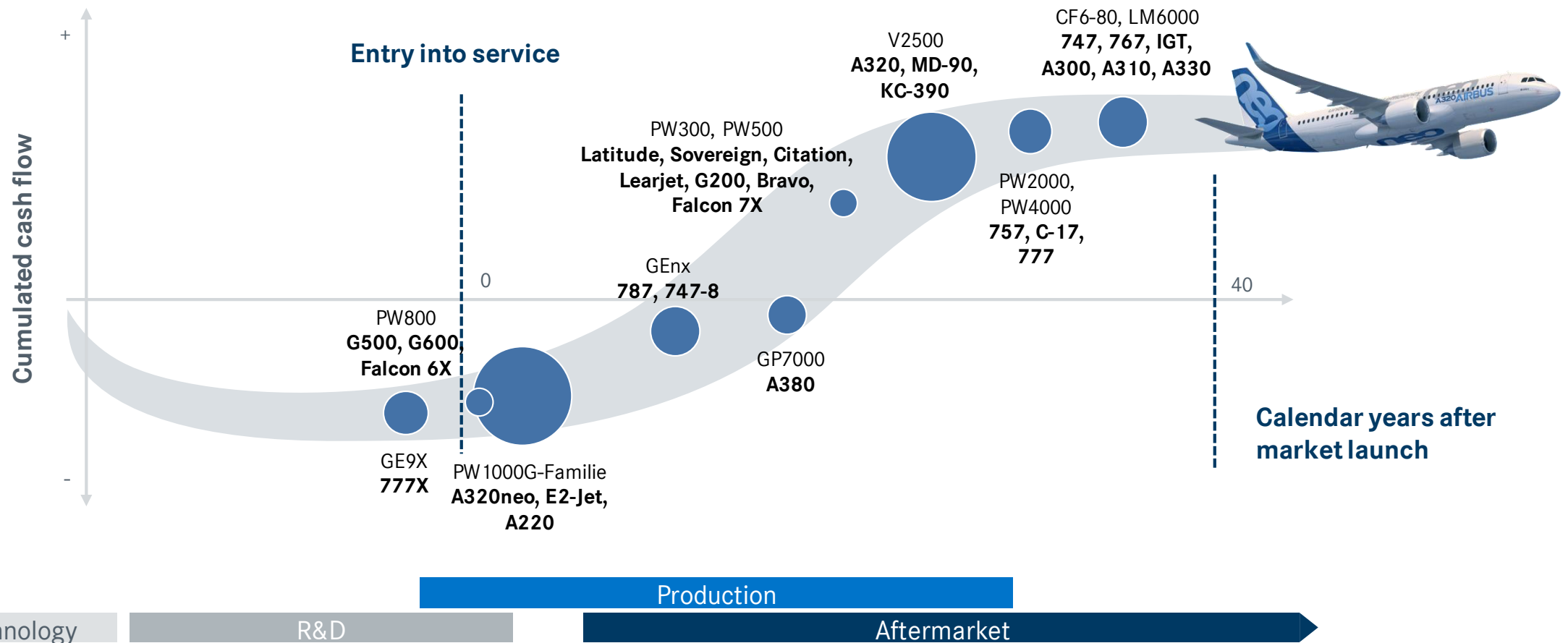

Our track record: partners and customers appreciate MTU's excellence

Commercial OEM business



Share of total revenues ca. 25%

Balanced product portfolio in all thrust categories

Decades of partnership with OEMs

Military OEM business



Share of total revenues ca. 9%

European and U.S. engine programs

Leading partner of the German Armed Forces

Commercial MRO business



Share of total revenues ca. 66%

Services: maintenance, leasing and asset management

Direct customer business, partner of OEMs and airlines

MTU group fiscal year 2022:

Revenue € 5.3 billion / EBIT € 655 million



3 Our expertise

MTU possesses unique capabilities and has a wealth of know-how.

Boasting comprehensive system expertise, MTU focuses on five core engine competencies - three core components and on unique manufacturing and maintenance processes



Engineering



Manufacturing



Maintenance

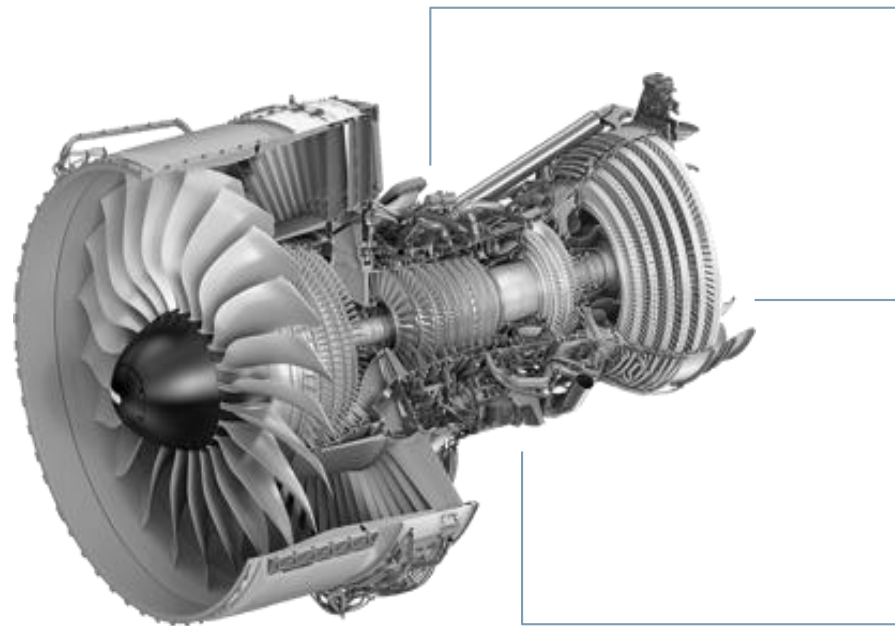

**High-pressure
compressor (HPC)**



**Low-pressure
turbine (LPT)**

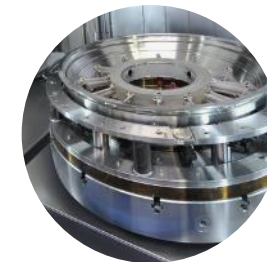

**Turbine center
frame (TCF)**

The geared turbofan is setting new standards - together with our partners, MTU will continue to expand its technological leadership in the future

1st generation geared turbofan - today

16%
reduction in
fuel burn

Approx. 75%
reduction of the
noise footprint

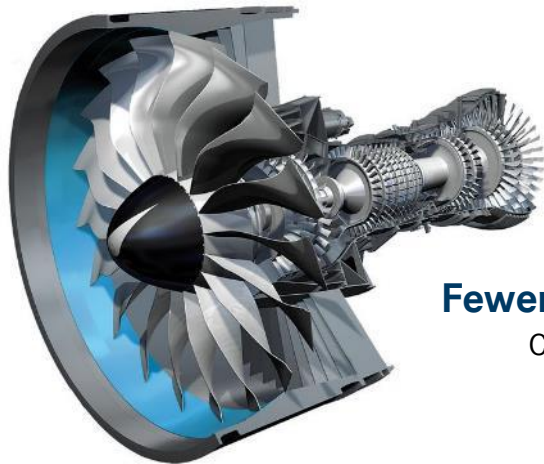

Fewer emissions
CO₂ / NO_x

MRO cost savings

25% fewer stages, 45% fewer blades, lower operating temperature

2nd generation geared turbofan – EIS 2030+

Lowest fan-pressure ratios at very high bypass ratios
BPR 14-20*

10%
further reduction in
fuel burn compared to
1st generation

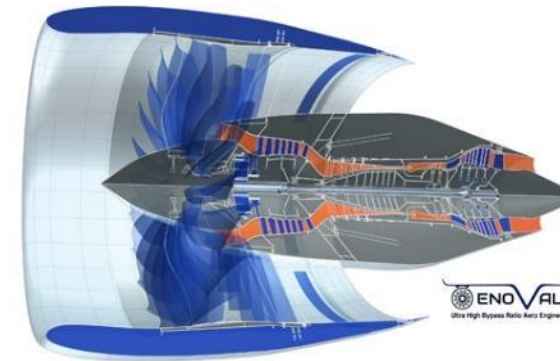

-10EPNdb
noise (cumulated)
compared to
1st generation

**Temperature-resistant
lightweight** materials

High-speed,
highly efficient
expansion system

Source: P&W | * BPR = Bypass Ratio | ** OPR = Overall Pressure Ratio

New Concepts

Evolutionary

Gen2 GTF

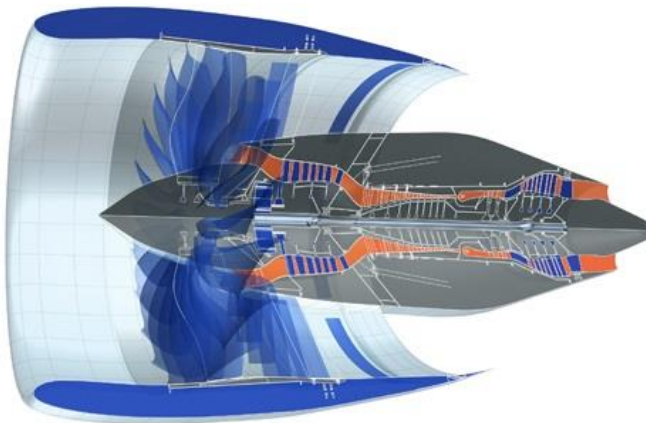

Minimum 10% reduction in fuel burn resp. energy consumption, -10EPNdb noise (cumulated) ¹⁾



Revolutionary

Water-Enhanced Turbofan (WET)



Up to 20% reduction in fuel burn resp. energy consumption, significant reduction of the climate impact, -80% NO_x¹⁾ and contrails



Flying Fuel Cell

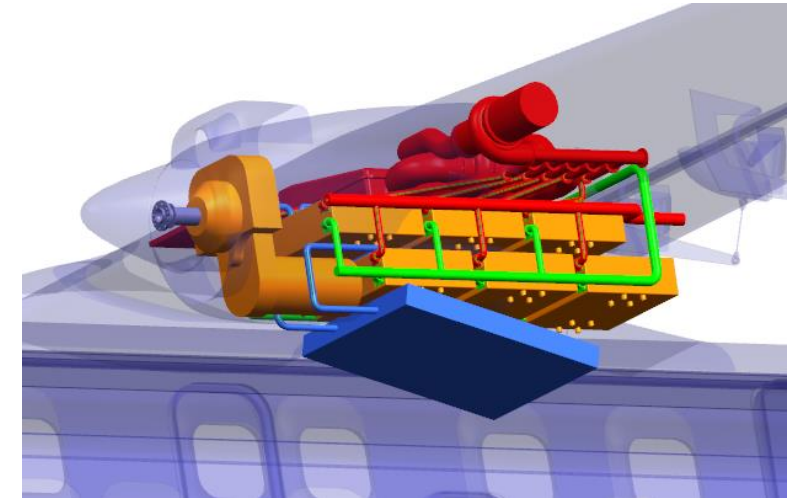

-100% CO₂ and NO_x¹⁾ and further reduction of contrail formation => almost climate neutral



We boast about 11,000 innovative and competent engine experts



Approx. 55

different nations
work under the umbrella
of MTU Aero Engines

Approx. 14 years

is the average job tenure
of MTU's workforce
(in Germany)

Approx. 80%

of the total
workforce are
engineers or technicians*

More than 350

apprentices at
German locations

*incl. scientists

With our locations worldwide we are close to our customers

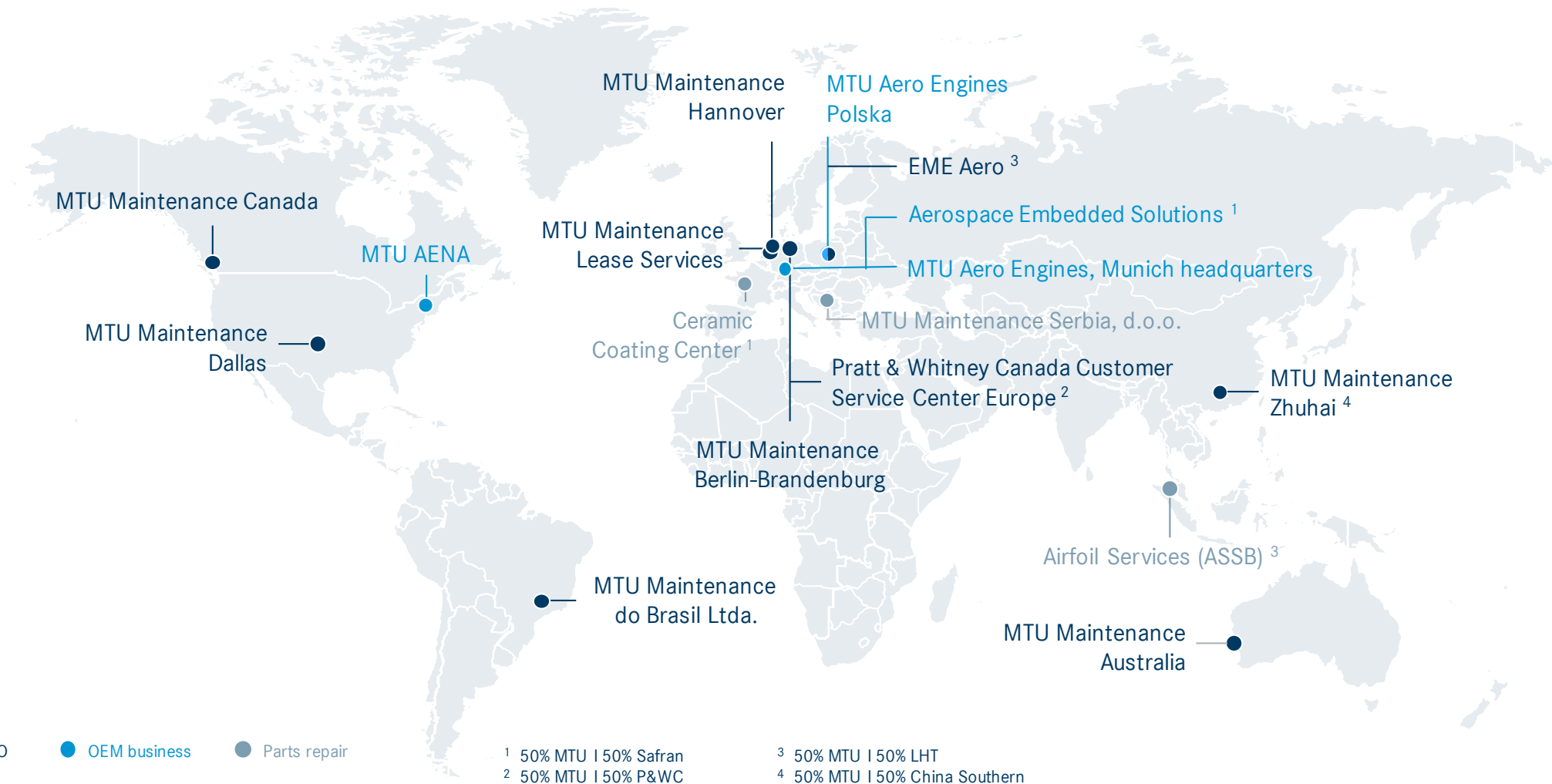

4

For questions relating to...

...our **company**



...our **commercial engine business**



...our **commercial service portfolio**



...our **military engine business**



...our **military service portfolio**



...our **technological expertise**



...the **sustainability** of our products



...our **financial figures**



...**job opportunities** at MTU



Click the relevant icon for more information



Working in the MTU IT department

What do we do?

“We create and maintain the IT landscape for MTU’s business – today and tomorrow”

- **Drive**
 - Adept new technologies / Establish new IT systems
- **Maintain**
 - Update / Implement new features for MTU’s existing IT landscape
- **Run**
 - Operate existing IT infrastructure and applications

What do I do?

- IT-project lead:
 - Implementing/Supporting different software solutions
 - Coordinating digital assistance projects (e.g.: AR/VR usecases)
- Running our DigiLab
- Developing small scripts (once in a while 😊)
- ...





Let's shape the future together!

Proprietary Notice

This document contains proprietary information of the MTU Aero Engines AG group companies. The document and its contents shall not be copied or disclosed to any third party or used for any purpose other than that for which it is provided, without the prior written agreement of MTU Aero Engines AG.