

# LS2 IR mechanics activity status and plan

S. Tanaka

2<sup>nd</sup> VTX general workshop in DESY

21<sup>st</sup> Apr. 2026

# LS2 IR issues (2026 Apr. snapshot)

- (KEK IR) Feasibility check of the 16mm diameter beam pipe
    - RVC: checking remaining items: Travel limiter, Guide pin and so on
    - Feasibility check of VTX assembly procedure
    - Mechanical stiffness of new BWD installation ring
  - FWD iVTX cooling pipe space check, ~~oVTX cable slot issue (FEM, BG)~~
  - (Vacuum) Bellows pipe movement (RF finger)for the earthquake
    - SR heating management (particularly around bellows)
    - Cooling management of the bellows pipe and QCS tip area
    - RF finger design in the Bellows pipe (can be parallel with beam orbit?,
  - (QCS) QCS head area stiffness (to stand RVC stress for vacuum tight)
    - QCS design/test(Nb3Sn and NbTi as a backup)
    - Vacuum sealing (for cryostat and beam pipe) design around the QCS head
  - (BG) BG estimation and mitigation
  - (STR) Additional Belle II support structure to mitigate displacement by earthquake
- Additional support structure to stabilize the QCS system (asap: on going)

Bellows  
RF finger test  
(Vacuum)



# LS2 RVC status (current RVC mock size is for **Nb3Sn** case)

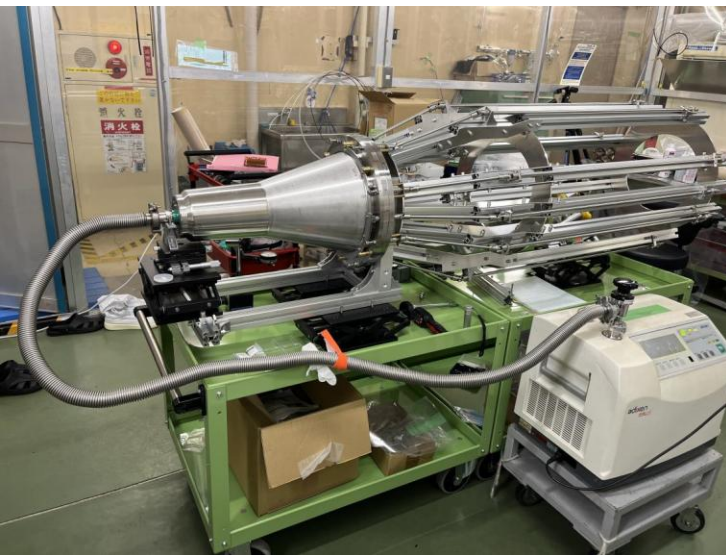
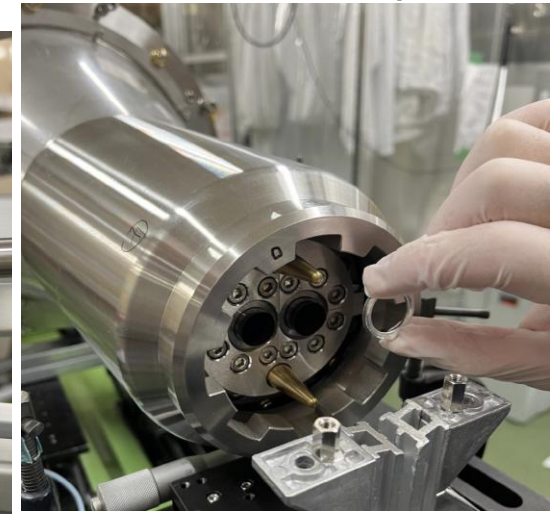

- RVC vacuum leak test has passed with remote rod control
- Seal test with asymmetric diameter o-ring is on preparation. Also metal o-ring positioning design
- Travel limiter design is on going



# RVC cap modification for the next step

Design modification plan of next version

## RVC-mockup2 → RVC-mockup2-Plus

[ RVC Capを作り替える前の改造案 ]

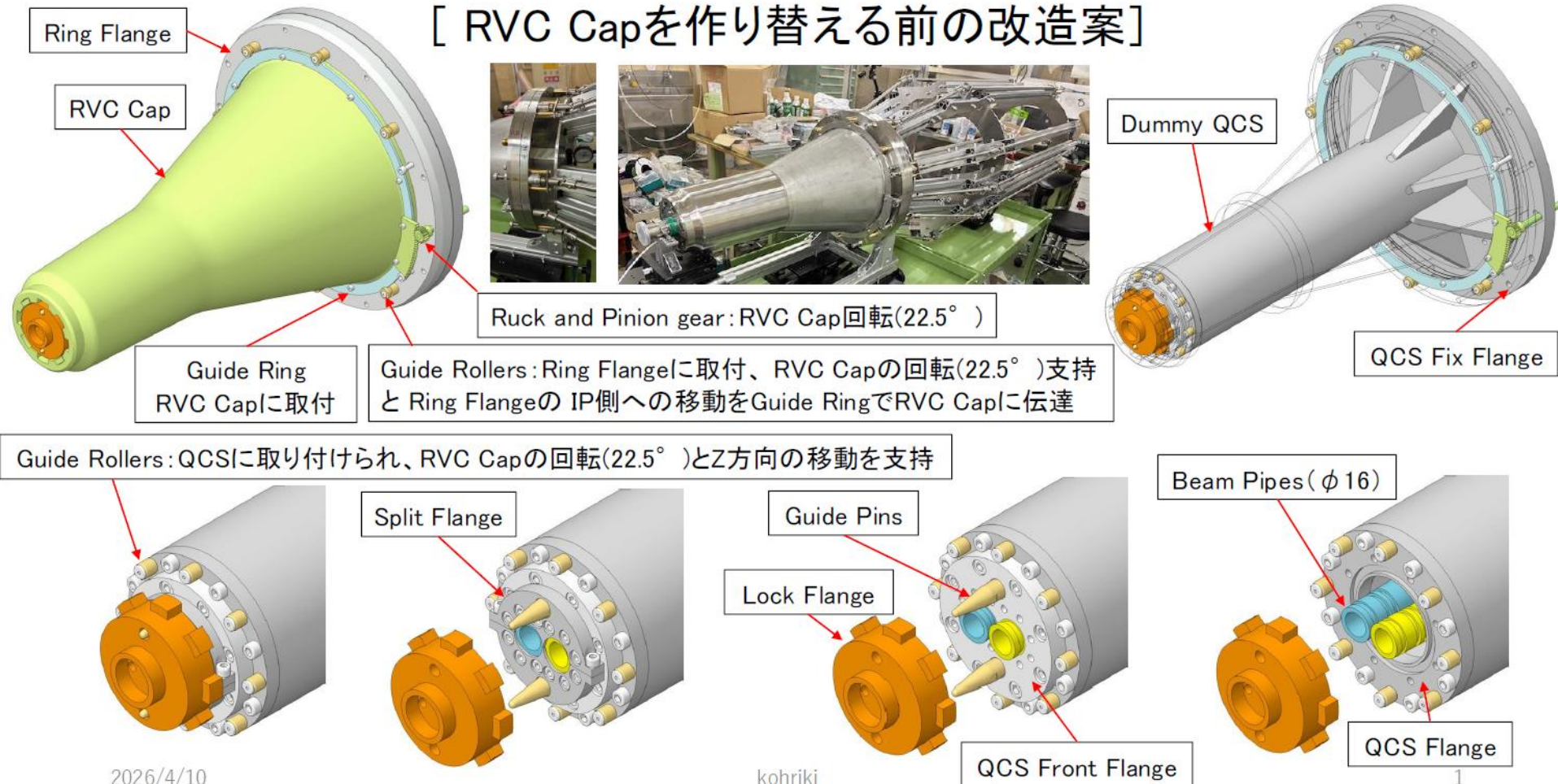

2026/4/10

kohriki

1

# RVC-mockup2 → RVC-mockup2-Plus

## [ RVC Capを作り替える前の改造案 ]

Current Design  
RVC-mockup2

Modified Design  
RVC-mockup2-Plus

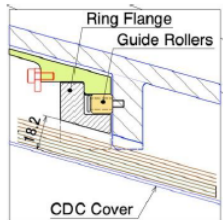

③ CableやPipeを通すための切り欠き

QCS側も切り欠く

③ 切り欠きと干渉するため、Guide Rollerを円周方向に45° 半径方向に2mm内側に移動

③ Pinion Gearを内側に移動  
CDC Coverと干渉するため

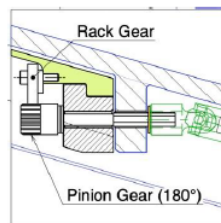

③ Rack GearとGuide Ringを小さくする

Guide Rollerの代わりにRack Gearの位置決めに兼ねたZ方向のガイドを追加

BWD region cabling exercise – D = 7 mm



BWD Exercise with n-1 cables

BWD Exercise with n cables

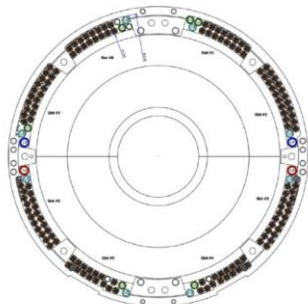
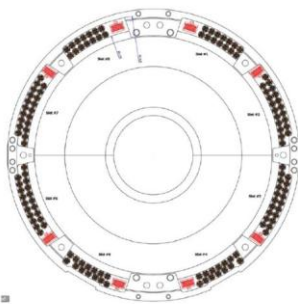

- Modification for Cable space btw. RVC and CDC
- **Careful check is necessary:**
  - Space allocation of the oVIX services
  - Cooling pipes for iVIX, bellows pipe, IP beam pipe

# RVC-mockup2 → RVC-mockup2-Plus

Summary of next version of RVC mock design (other than RVC size change(next page))

Φ8穴をBeam Pipeの中心にするとLock Flange側の穴に当たるので、穴の中心を1mmずらす

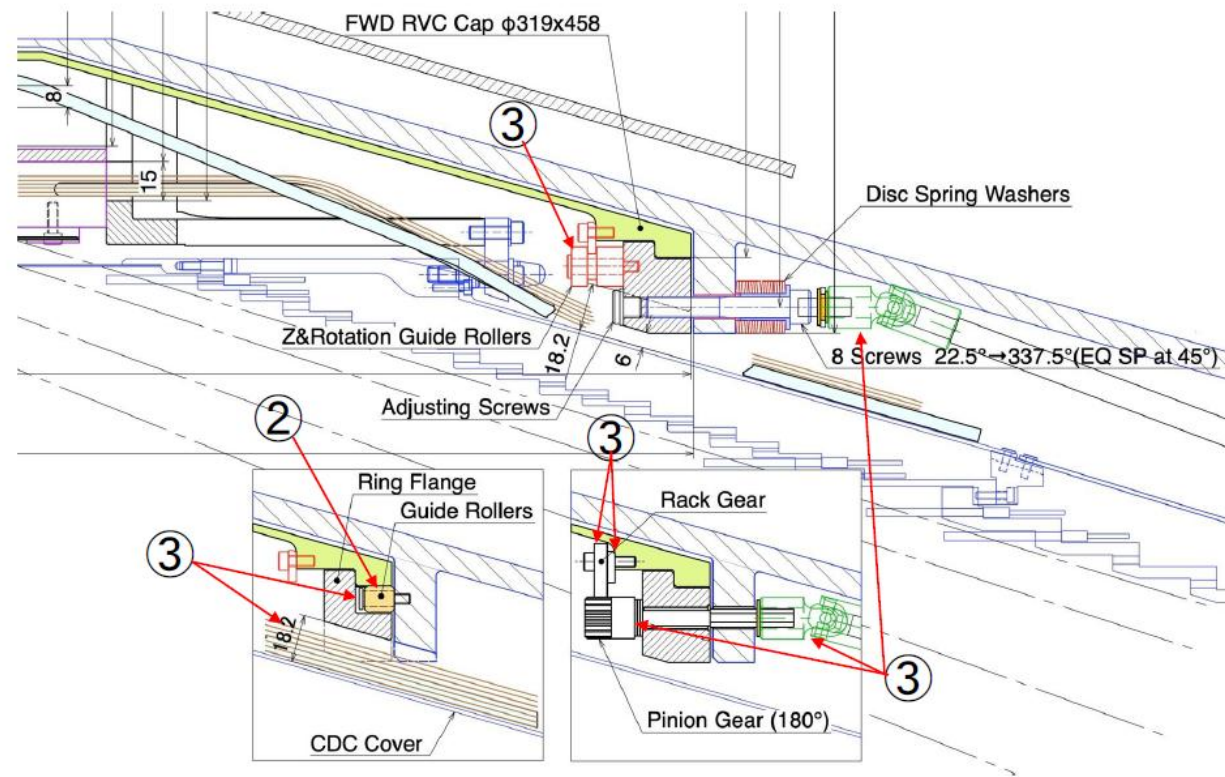
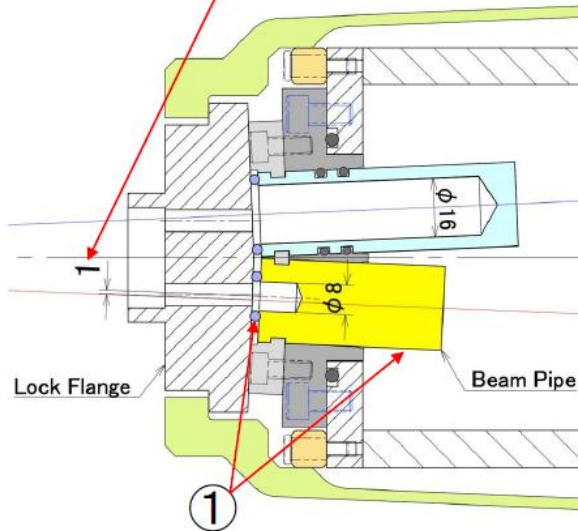

2026/4/10

kohriki

7

1. QCS beam pipe mock design (LER inlet: 8mm diameter)
2. Guide roller design to centering RVC system with respect to the QCS axis
3. Design update to make space for the VTX services

# RVC-mockup2 → RVC-mockup3

## Next next Version of the RVC mock design

### ④ QCSの先端部をIP~360mm、 $\phi 158$ (Nb-Ti)の仕様に変更

- Dummy QCS をそのまま流用して先端部にあるQCS Flangeを作り替えるのが一番簡単だが、RVC Capも作り替えるので、それらと合わせたQCS Capの強度計算の結果を踏まえて構造を考える。

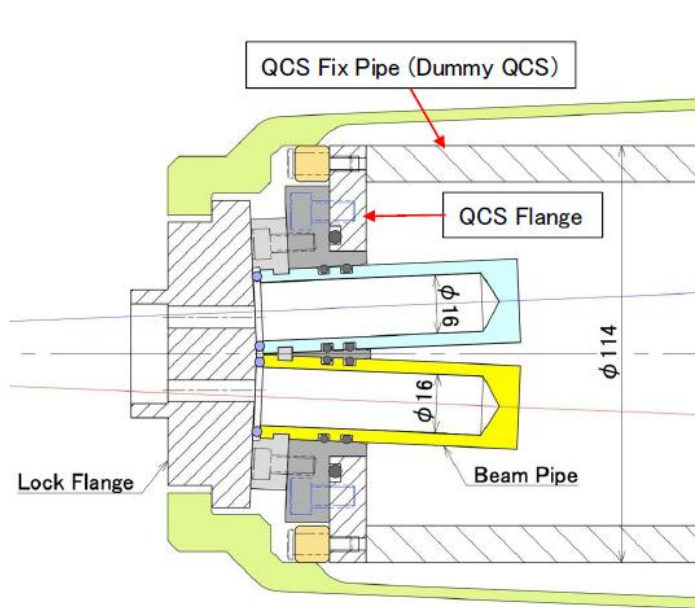

Current design(for Nb3Sn)

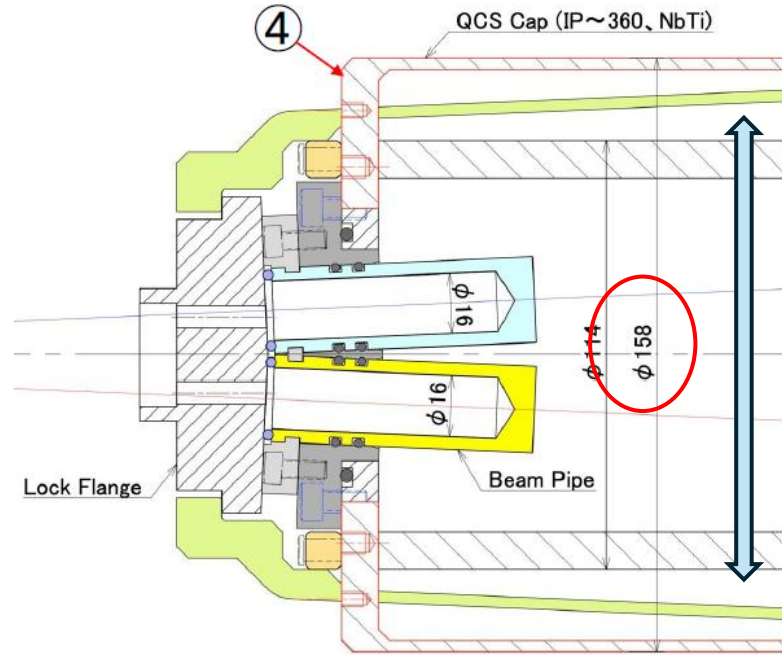

RVC modification(for NbTi)

2026/4/10

kohriki

9

- RVC size change( Nb3Sn -> NbTi )
- FEM analysis (of RVC and also QCS cap is mandatory)

# RVC-mockup2 → RVC-mockup3

## [ RVC Capを作り替える案 ]

- ⑦ Lock Flange位置決め用Guide Pinの形状を決める → もっと大きくする必要がある？
- ⑧ Lock FlangeのTravel Limiterを考える → スペースの関係でGuide Pinの左右に配置して合計4本にする？

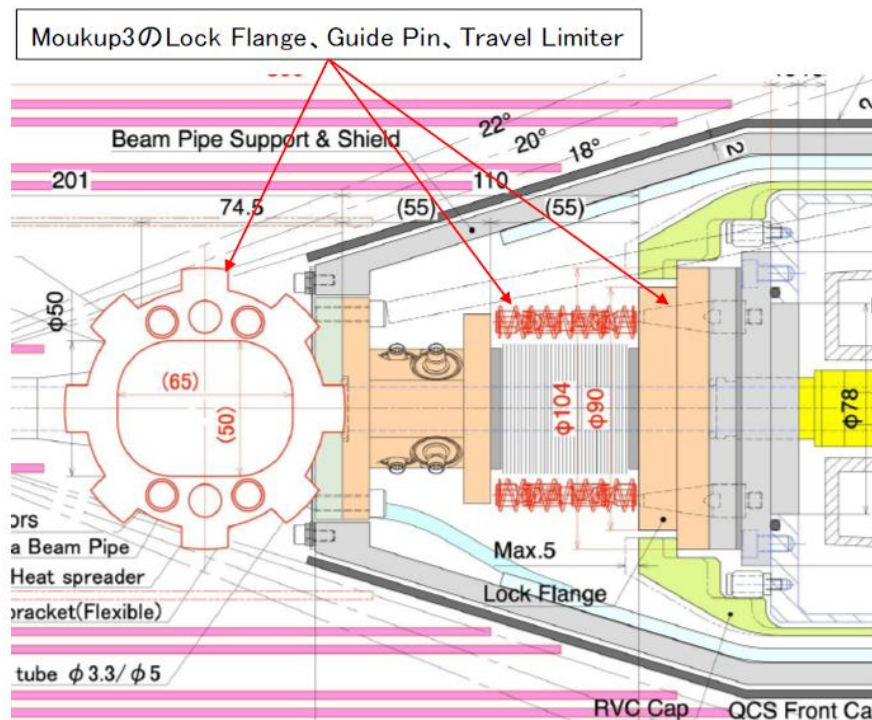
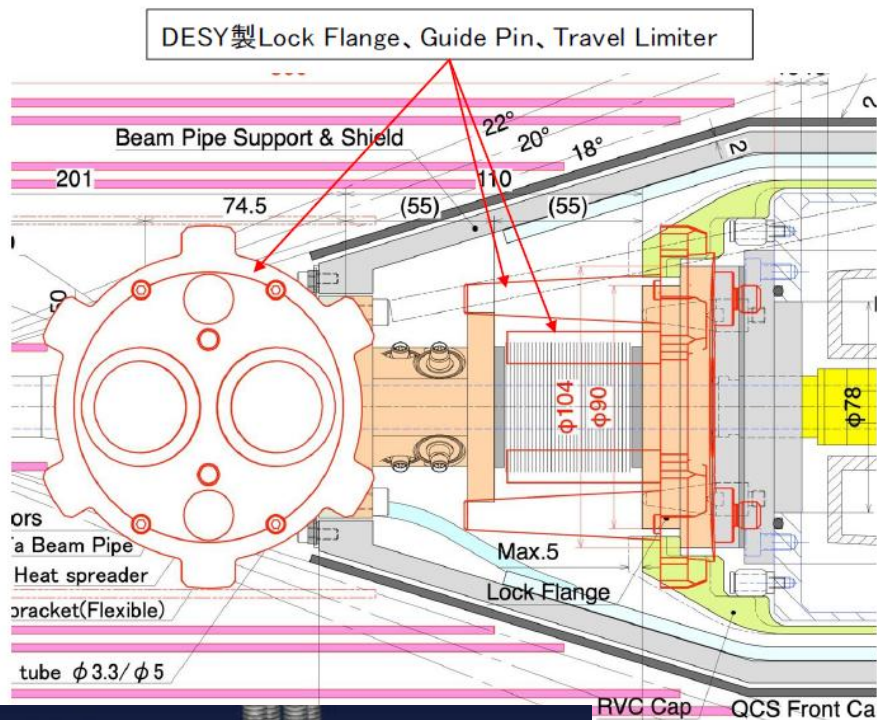

kohriki

14

- Lock flange and travel limiter design is starting
- Because of limited space, the travel limiter should be 4 smaller structure
- Guide pin should be enlarged than current design
- Space for the cooling of the bellows pipe is big issue

8

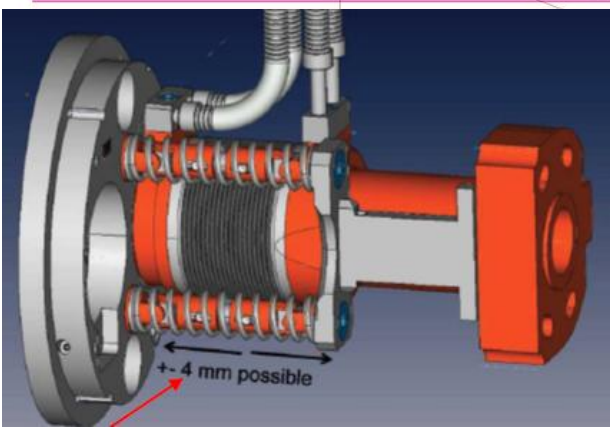

# QCS status and near-term plan

Ohuchi, Arimoto, Aoki

Nb<sub>3</sub>Sn test :

## Coil Fabrication and Test Schedule (FNAL-KEK)

- **February 2024:** Start of prototype coil fabrication at FNAL.
- **April 2024:** Start of coil fabrication jig production at KEK.
- **April 20–24, 2026:** Coil fabrication test at KEK using the **improved fabrication jig**.
  - **Vadim Kashikhin (FNAL)** visits KEK during the test.
- After the test, if the prototype passes the **FNAL review**, fabrication of the **first coil for the mirror magnet** will begin.

2024年2月26日QC1P FNALコイル試作



# Nb<sub>3</sub>Sn QC1P Magnetic field calculation

Conductor geometry (rectangular cross section)

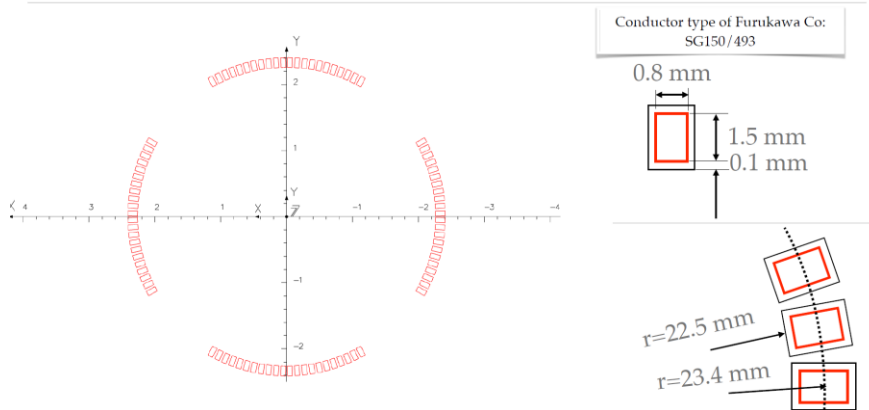

2024年5月FNAL-KEK-古河-Nb3Sn QC1P開発技術打合せ

## R & D magnet 3D model

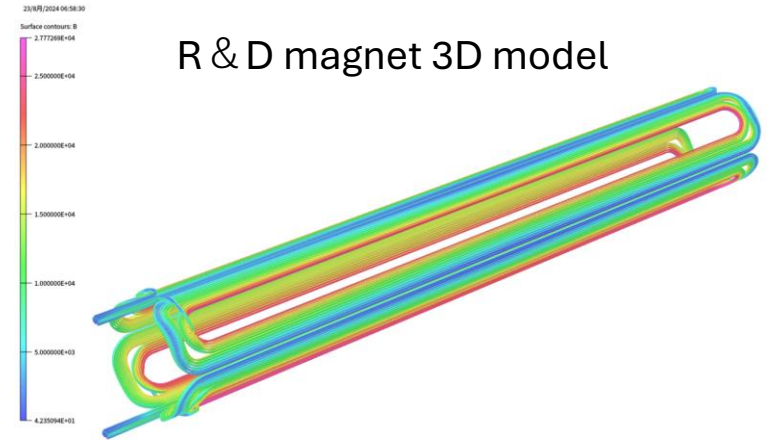

The maximum magnetic field is generated at the coil end, and its magnitude is 2.8 T.

2024年8月FNAL-KEK-古河-Nb3Sn QC1P開発技術打合せ

I=1665 A

## Mirror magnet design

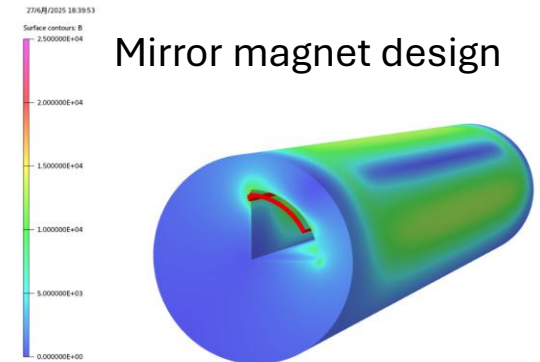

2025年7月SCマグネット打合せ

By inserting 1/4<sup>th</sup> coil in the iron structure, quad pole magnetic field test can be applied

# QCS schedule

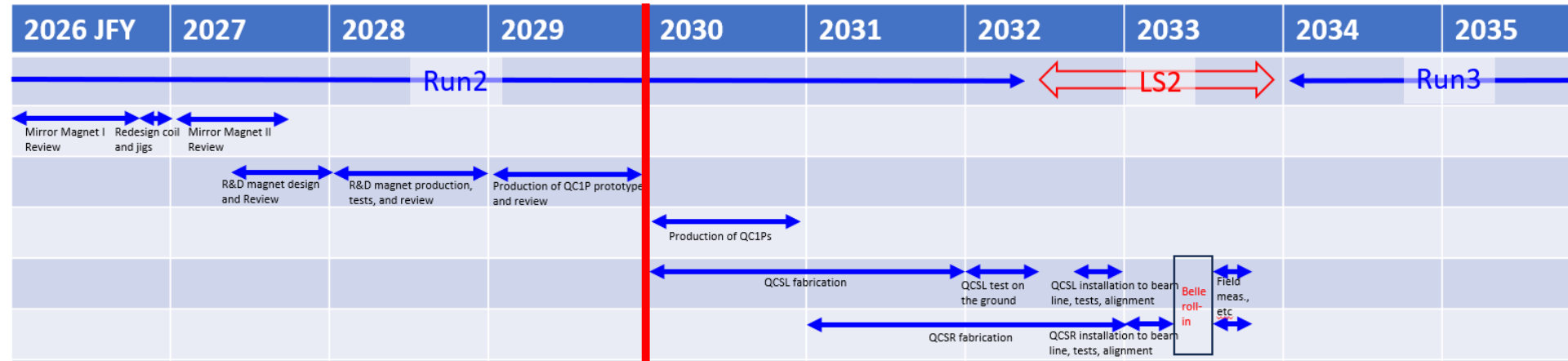

- QCS Cryostat design, cancel coil design and other service design will be performed in parallel
- The design decision timing (Nb3Sn or NbTi) should be clarified

# QCS and beam pipe integration

Shibata

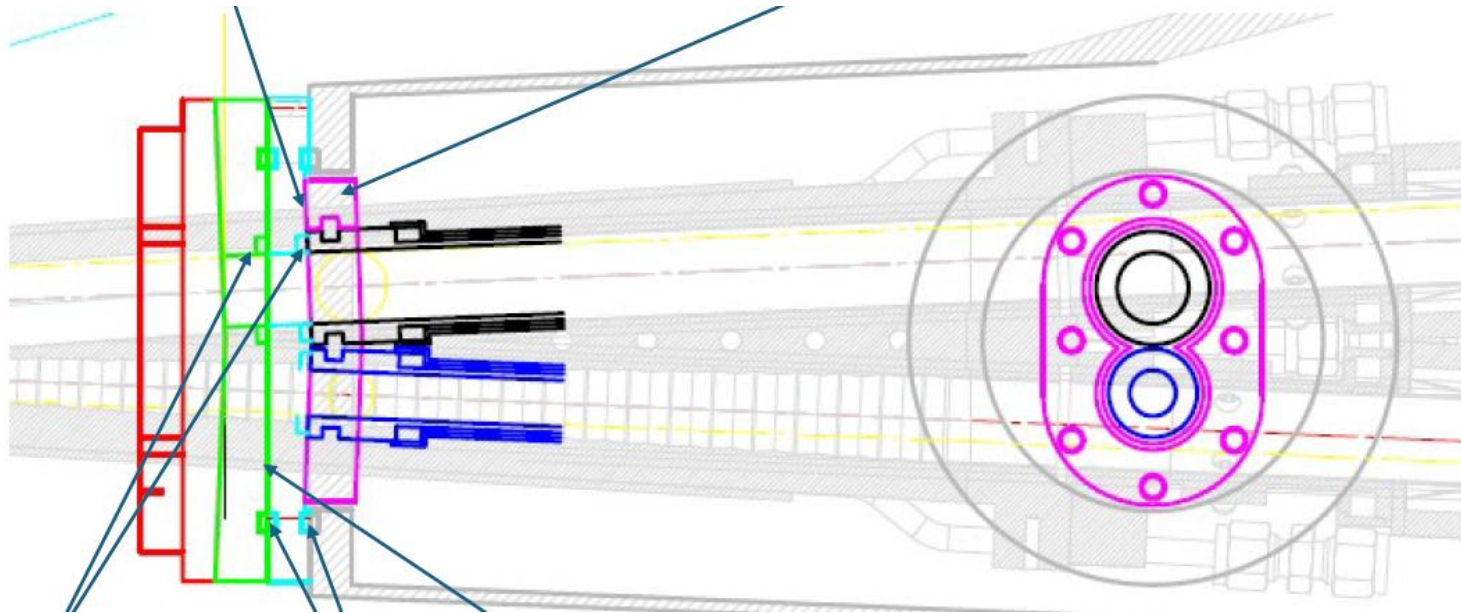

- Very rough sketch of the part allocation and integration plan was introduced by Shibata-san
  - We need check vacuum tight feasibility by M6 screw(less strength)
  - Cooling will be also concern by many of parts
    - **There is no active cooling**

**対策-2: Fix vertical surface at skirt**

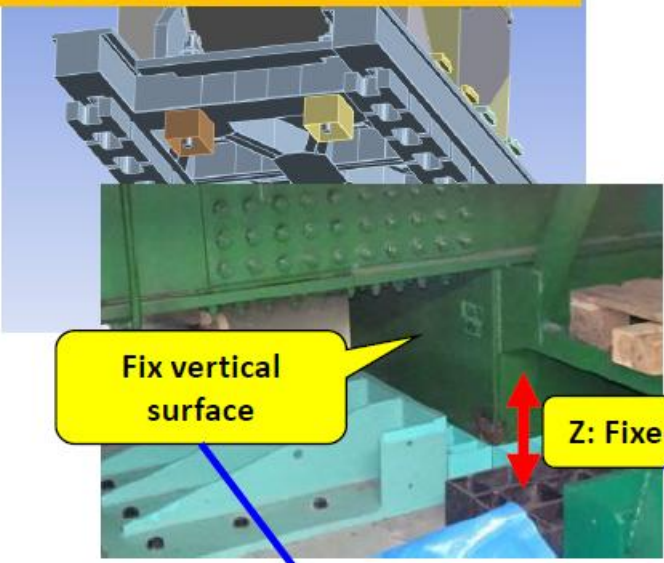

**Original**

	X (Perpend.)	Y (Beam)
Resonance (Hz)	3.6	4.2
Rel disp. (mm)	4.6	6.7
Stress (MPa)	1857	2031

→ N.G.

→ **Fix vertical surface + Fix vertical direction**

	X (Perpend.)	Y (Beam)
Resonance (Hz)	10.7	7.5
Rel disp. (mm)	0.7	1.7
Stress (MPa)	81	130

→ O.K.

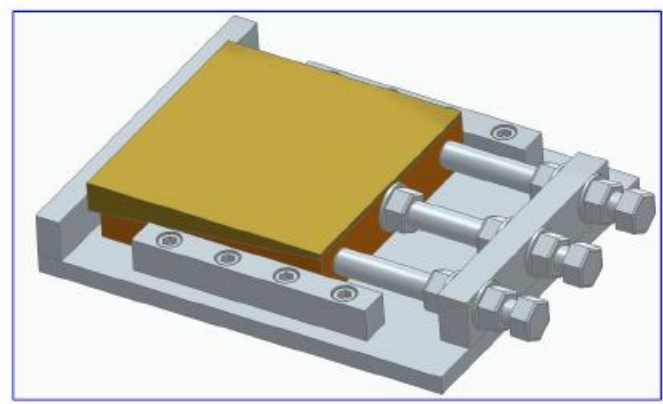
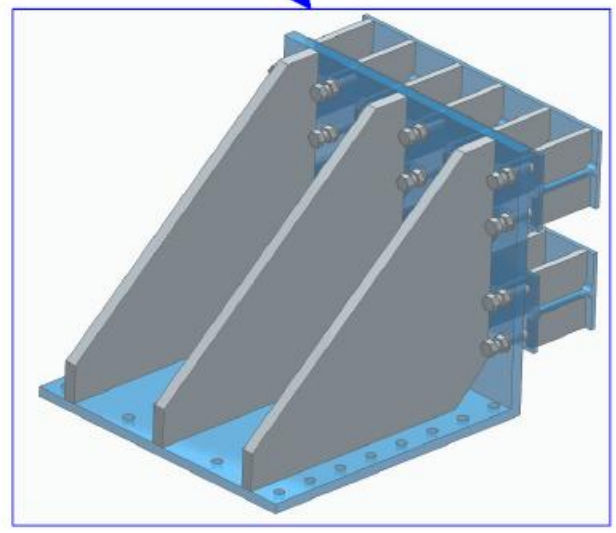
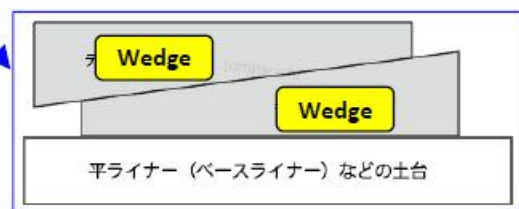

# Next step: Additional side support btw. Belle and QCS bridge

**Proposal-3: この検討は未だです**

**Detailed design has Not started yet, Just on discussion**

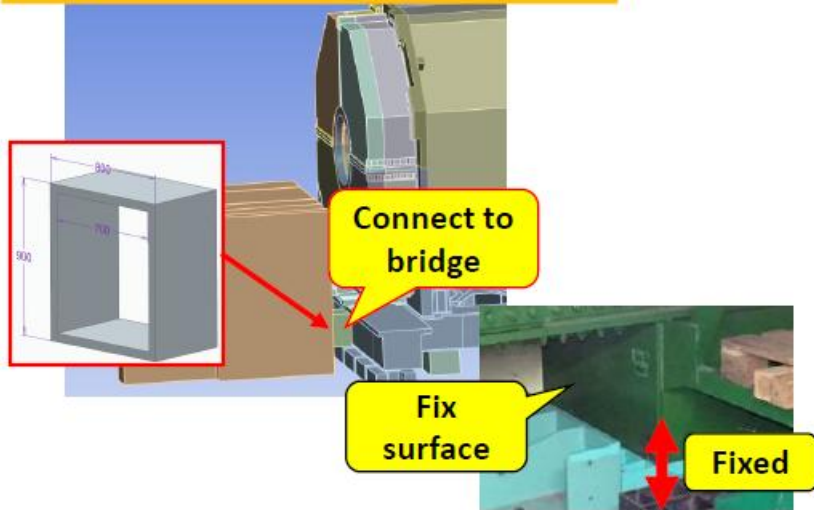

→ Connect to bridge +  
fix (vertical surface + vertical direction at skirt)

	X (Perpend.)	Y (Beam)
Resonance (Hz)	12.1	11.1
Rel disp. (mm)	0.5	0.6
Stress (MPa)	84	133 → O.K.

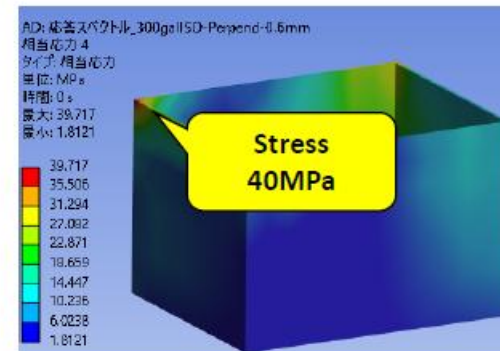
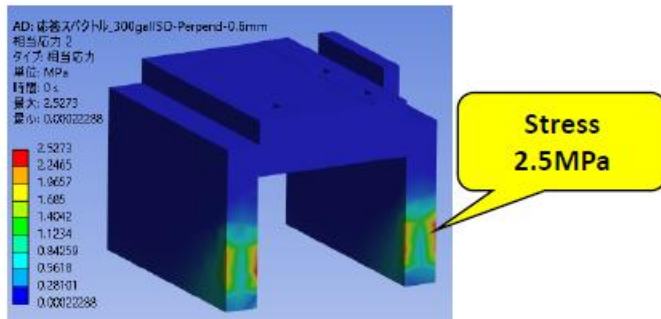
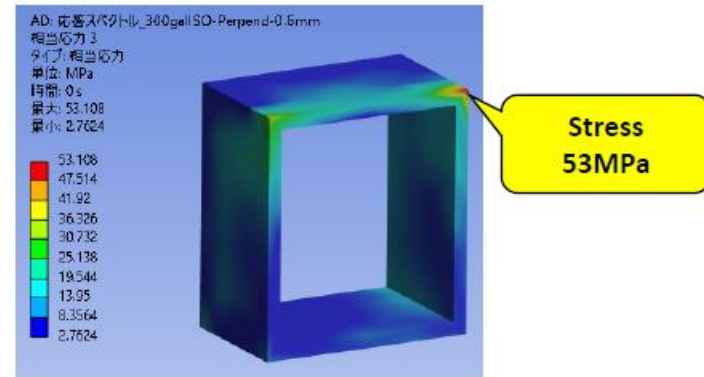
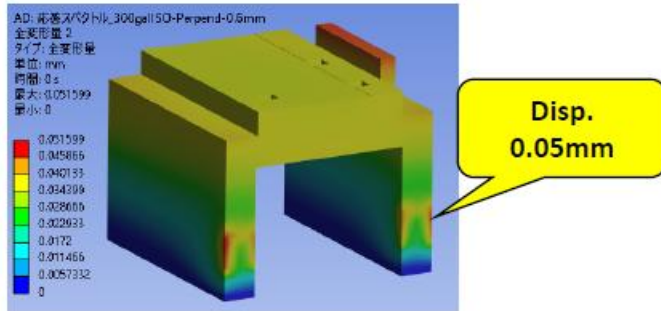

# LS2 integration

Try to set 5W1H

(Sorry BG estimation is not included.)

# Who/which group is involved in the integration discussion ?

- **KEK VTX mechanics**
  - IP beam pipe, RVC, VTX mechanics integration
- **Belle II VTX group (WG4/WG5)**
  - Chairs: S. Bettarini(WG4), C. Irmler (WG5), J. Baudot (VTX leader)
  - iVTX (half mount, cooling, service integration including PPs and Docks)
  - oVTX(attachment, cooling, service integration)
  - VTX integration/installation\*\*
- **KEK LS2 IR meeting (KEK)** S.Tanaka. T. Oki (machine group)
  - Member: KEK Belle II, ITDC, QCS, Magnet, optics, vacuum
  - **IR design(space allocation)**, beam pipe integration, VTX integration/installation\*\*
  - QCS, Bellows pipe, Shields, BG estimation, SR heating
  - LS2 schedule (QCS removal, Belle II roll-out and more)
- **VTX-KEK IR common meeting**
  - Special meeting in the Every B2GM
  - Deciding inter-group issues (i.e. space allocation)
  - **oDC, iTT group should join this meeting**

Who, How to organize the inter-group discussion items.

- **oDC(iDC) group**
  - K.Inami(chair)+ \*\*\*\*\*
  - oCDC production, commissioning, installation, integration with iDC(iTT)
- **iTT group**
  - J.Ott (FTL: Hawaii), D. Pitzl(STL: DESY)
  - iDC(iTT) production, commissioning, integration with oDC, VTX
- **CDC group (Y.Nakazawa)**
  - **Liaison** for the installation/transportation and commissioning setup

**We need one integration meeting**

# Very Rough action item arrangement in LS2 (Schedule check points)

- Concrete shields removal (Vacuum group)
- Open Belle end-yoke, Yellow stage attachment, scaffolding setup (Belle STR)
- Magnets (behind QCS) removal (Magnet group)
- QCS extraction(QCS, vacuum, cryogenics)
- Endcap removal (Belle STR)
- VXD removal (VXD)
- Removing scaffoldings, Yellow support stage, Belle support brackets and closing End-yoke (Belle STR)
- Belle roll-out (Belle STR)
- QCS dismantle from IR (QCS)
- Magnet removal in Tsukuba straight section
  - Installing new magnet system
- QCS rail extension at IR (QCS)
- New QCS installation to IR (QCS)
  - QCS alignment (QCS+magnet)
- Belle Roll-in (BelleSTR + magnet)
- Opening End-yoke, Yellow support stage, scaffoldings setup (Belle STR)
- VTX installation (VTX)
- QCS insertion (QCS, vacuum, cryogenics)
- Endcap attachment (Belle STR)
- Closing End-yoke (Belle STR)
- Concrete shields installation (Vacuum)

When +where + who during the LS2

(at Roll-out position)  
CDC removal(CDC)  
oDC+iTT installation(CDC+?\*)

Additional duration  
than LS1

# Where<sup>1</sup>: Space for the sensor integration

- Tsukuba hall B1 (SVD space at present)
  - oVTX mechanics preparation
  - oVTX ladder mount and system test
  - iVTX acceptance check if necessary
- Fuji hall B4 clean booth (We need schedule to negotiate with space organizer)
  - oDC mechanical work
  - oDC wire stringing
- A clean booth in Fuji hall (not defined yet)
  - for the iTT mechanical integration
  - Space request and timeline proposal is necessary to get reservation.
  - Other requests?

# Where 2 : Commissioning just before the installation

## • VXD clean booth

- IP beam pipe + Shields integration
- RVC preparation
- VTX integration
  - iVTX attachment
  - oVTX attachment
  - VTX System test

## • ARICH booth

(Capability of CDC storage/test and extraction from the booth)

- ARICH maintenance space
- oDC + iTT integration
- oDC + iTT system test

PXD1 + phase 3 setup should be disassembled to switch activities

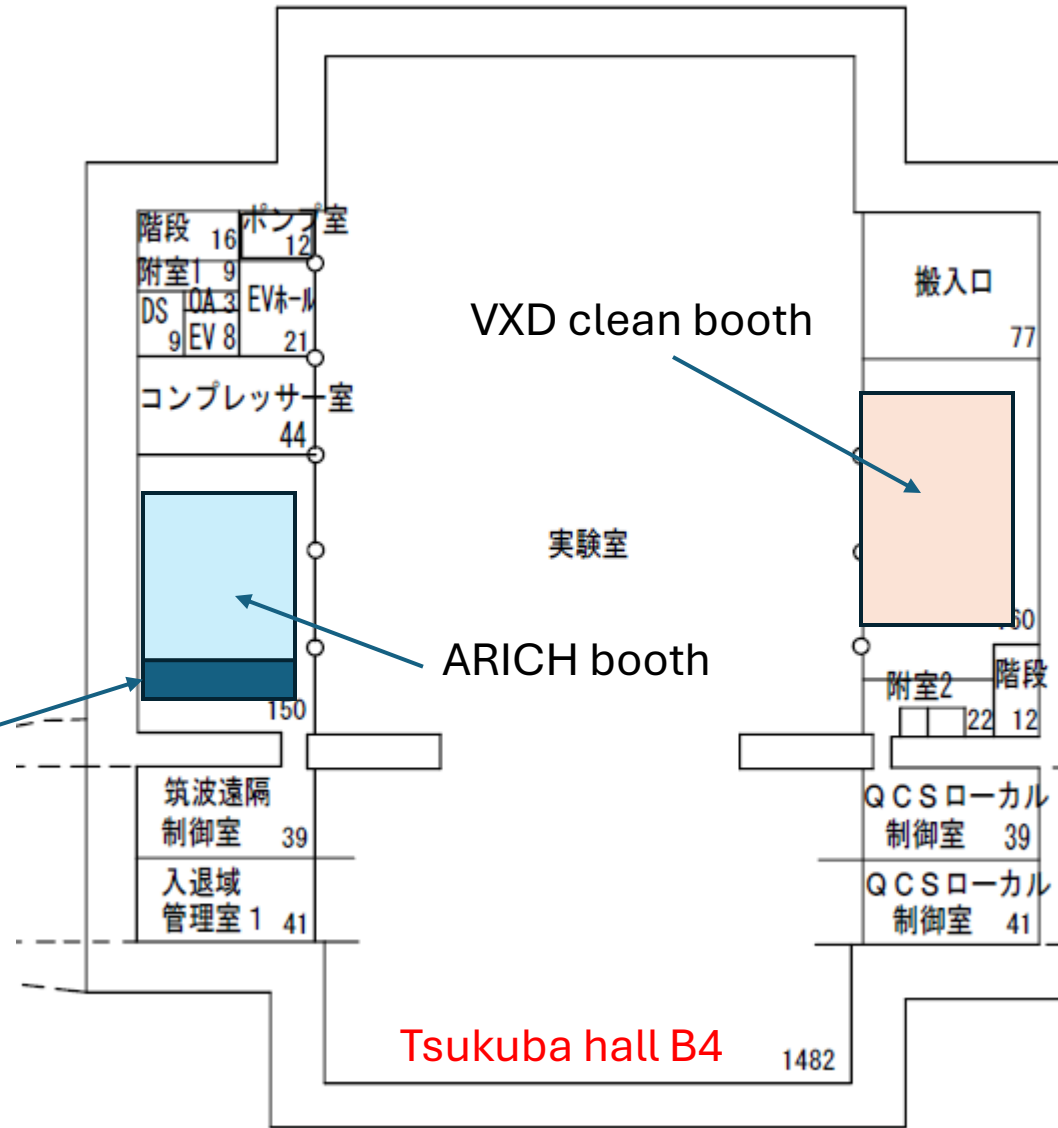

# Where 2 : Commissioning just before the installation

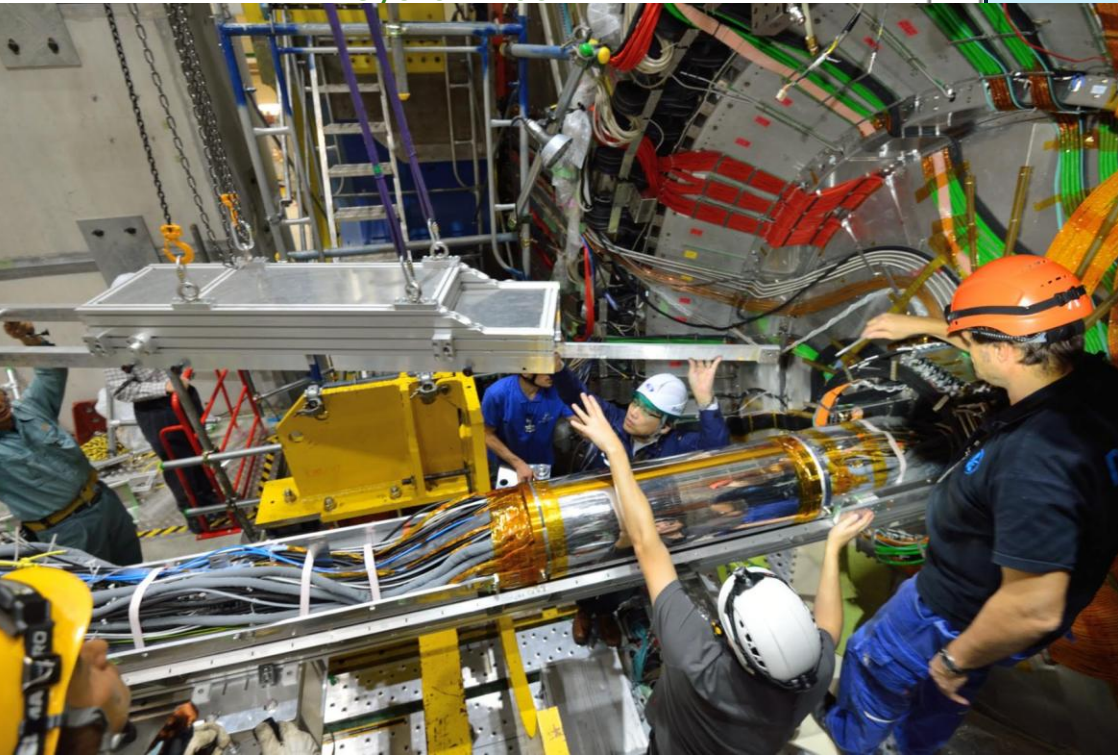
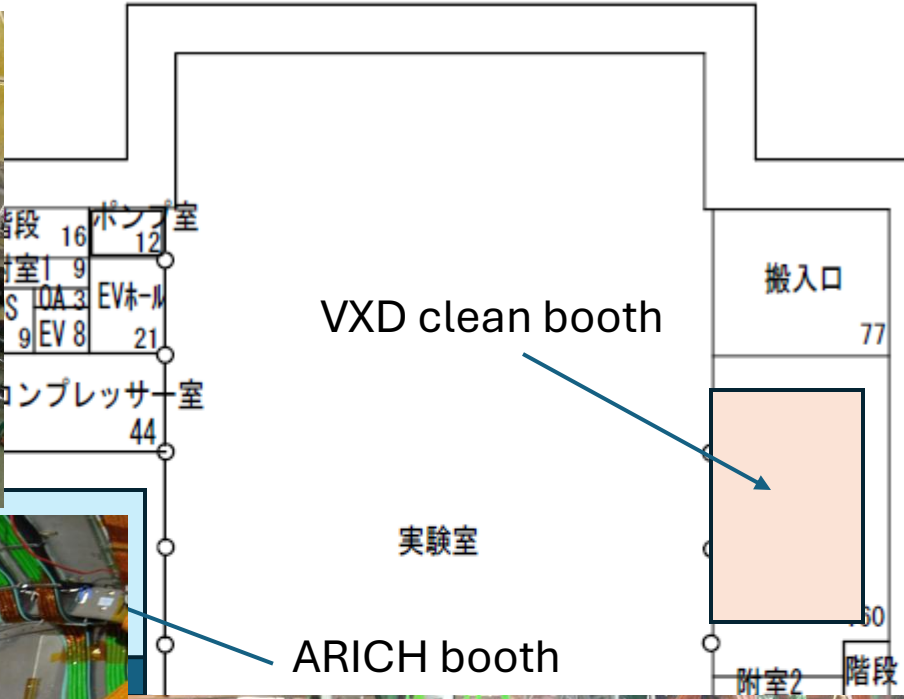

# Geometry of VTX, CDC and ITT volume for Belle II upgrade

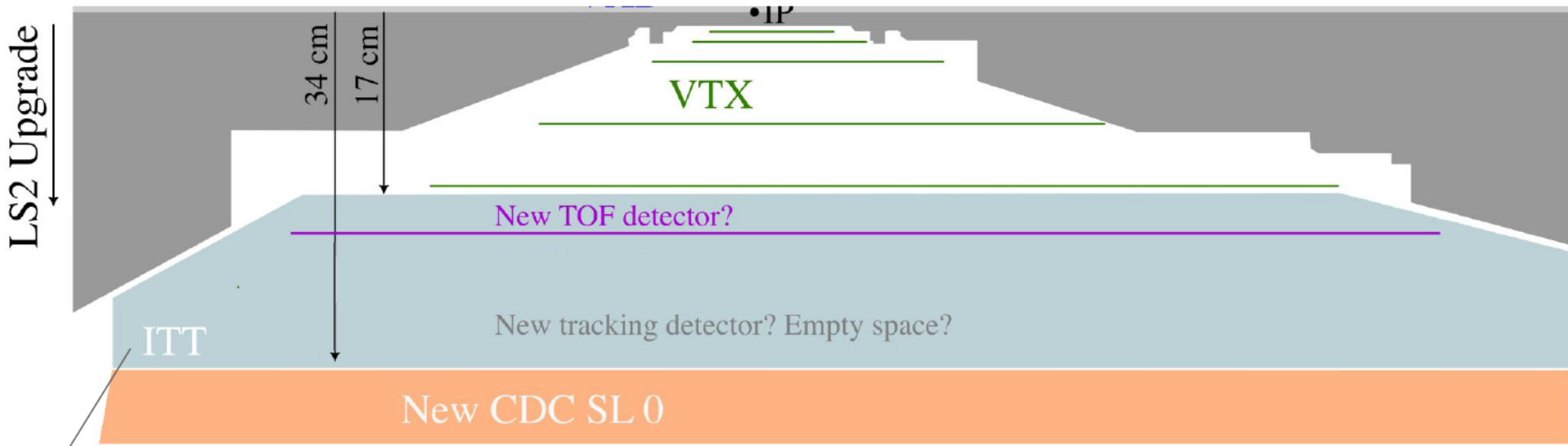

A Gap between VTX and new CDC => leaving tracks in this region uncovered -low pt tracks

**Proposal:** Let's add a detector here!



- Fast timing detector (PID based on TOF) -> ITT region (Inner Timing Tracker)
- Open to multiple detector options -> Silicon-based, Gaseous
- Short timeline -> Prefer existing and well-established technologies (design, readout, manufacturing, etc)

→ Identify a fast timing, practical solution that introduces acceptable material.

- Preliminary simulation to understand the performance

# Baseline plan (until July)

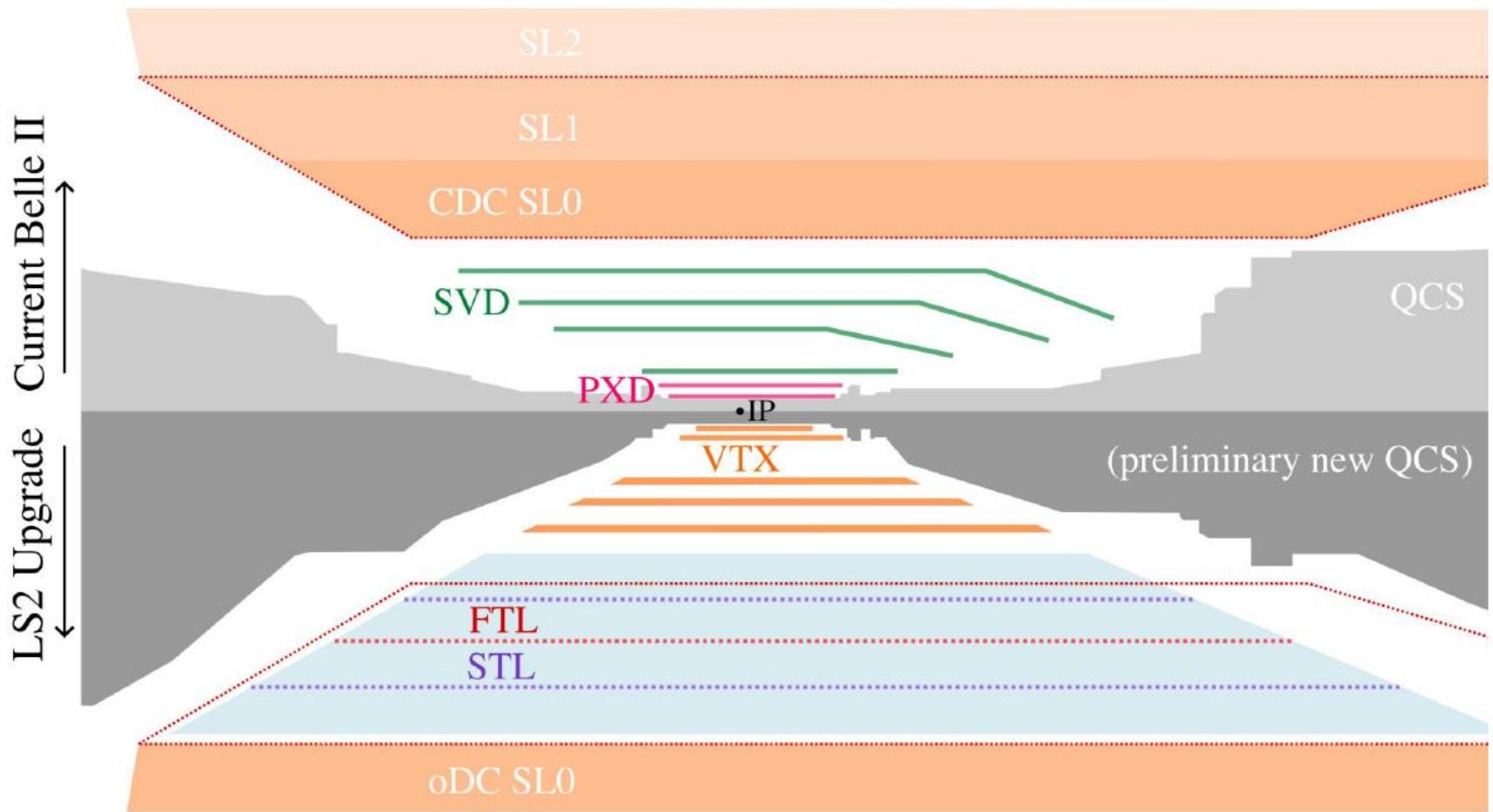

- CDC (SL0+SL1) area -> iTT (iDC as a fallback option)
- Possibility of the iDC replacement with iTT **at IR** after the LS2???
  - For the emergency case on the iTT schedule.
  - KEK IR group will take care of this fallback scenario negotiating with machine group

# Dividing discussion points

- CDC -> oDC + iTT (current proposal)
  1. The outer design of oDC and inner design of iTT should be identical
  2. Connection of oDC with iTT
  3. Side support mechanics space for iTT ladders
    1. Ladder design draft is necessary
    2. There is no historical template design for ladder mount by new system

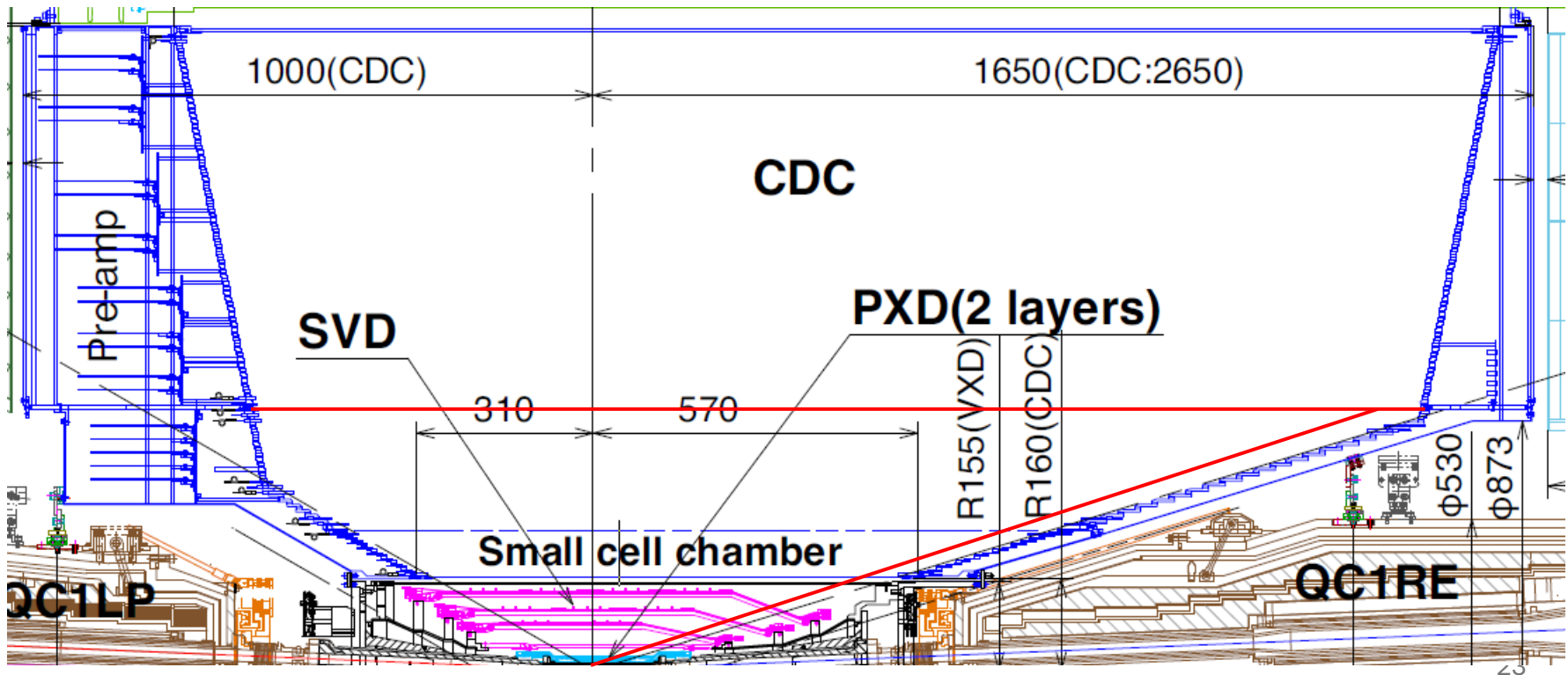

# 1, oDC outer design and iTT inner design

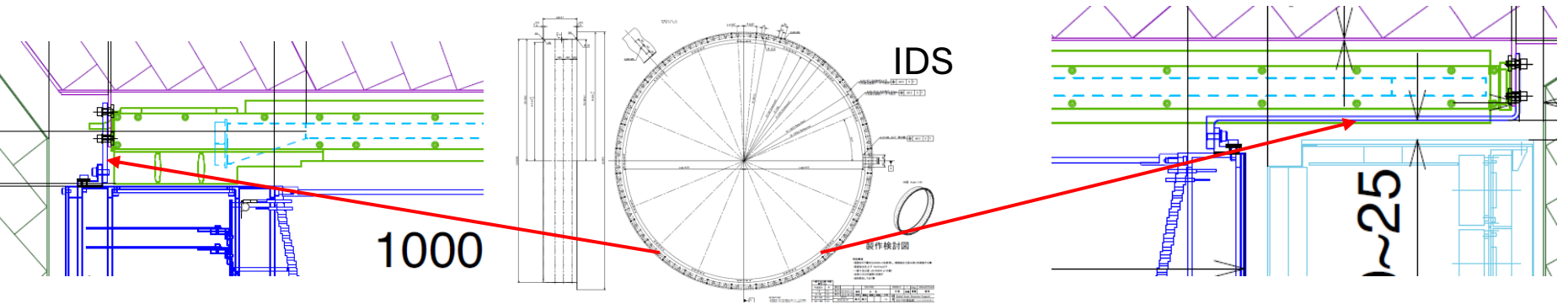

- oDC outer design should be identical with CDC's.
  - oDC is connected with the IDS.
- iTT inner design should be identical with CDC's.
  - So That VXD/VTX installation method and also New CDC installation procedure, which require the same inner design, can be identical.

VXD/VTX fixing in xyz

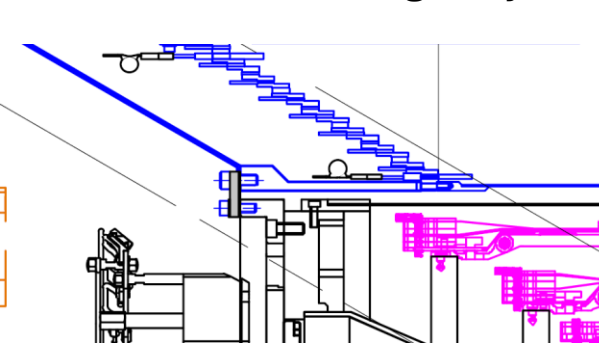

VXD/VTX fixing in xy by Pins

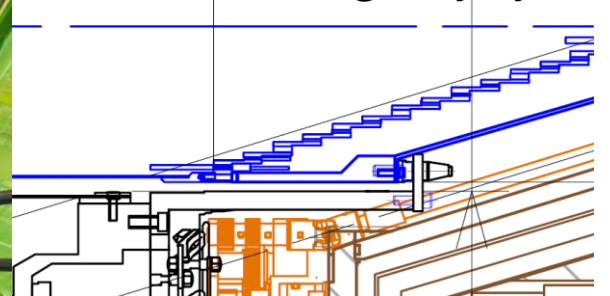

## 2, Requirements on the connection of oDC with iTT

CDC inner cylinder thickness is  $\sim 0.65\text{mm}$   
(CFRP 0.5mm+ AL 0.1mm + Epoxy resin 0.05mm=0.65mm)

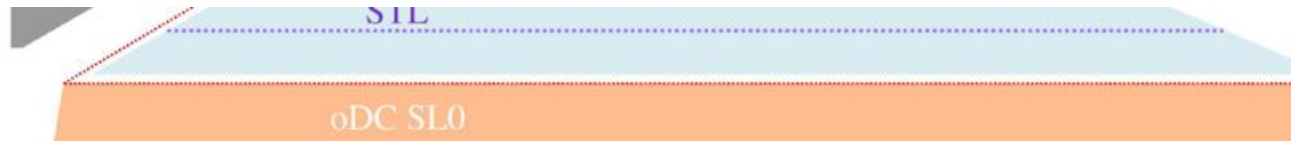

- oDC will be a gas chamber.
  - Inner structure should be gas tight and have enough stiffness to stand for the wire tension.
  - Adopting inner cylinder mechanical like design with the CDC inner cylinder? Or other idea?
- iTT requirements ?
  - Integration method (like VXD? Or like CDC Inner cell)
  - Sensor area coverage in the volume
    - $22$  (~~17~~)  $<$  Polar angle  $<$  150 degrees
  - Readout FE and cooling
  - Space for Docks?
  - Any other Mechanical requirements?
    - Next page in detailed

### 3, Side support mechanics space for iTT ladders



- There is quite less space even if polar angle coverage is changed from 15 -> 22 degrees.
  - iTT Ladder mount like SVD/oVTX is possible?
  - Cable/cooling pipe estimation (# and it's cross-section)

# iTT – Key Design Requirements

We'd like to know below subjects for the space allocation.

## Sensor Envelope:

- material budget
- Space for services (and ladder mount ideas if you have any)
- Assembly feasibility

## Readout:

- FPC routing (~50cm max.? Or not)
- Connector placement
- High-speed links & power
- Noise/grounding control

## Cooling:

- Total heat load
- Efficient conduction path
- Water-cooling interface?
- Temperature stability

## Dock location:

- Interfaces for FPC, power, optics
- Cooling manifold
- Easy access & replacement
- Low cable stress

## Mechanical Strength:

- Low deflection (how much?)
- High stiffness
- CTE management
- Alignment strategy

Minimum size of mount area FPC



# Summary on the IR activities

A base IR design/boarder has been agreed in Feb. 2026

- In particular, LS2 IR Boundary btw. SuperKEKB and Belle II VTX which is related with below groups:
  - IP beam pipe: **Japan VTX group**
    - Checking issues on the Smaller diameter pipe
  - New RVC mechanics : **Japan VTX group**
  - VTX mechanical integration proposal : **Japan VTX group**
  - New bellows design: **Vacuum group**
  - New QCS design : **QCS group**
    - Cryostat design incl. thermal management : **Nb3Sn -> NbTi case**
    - **Updating QCS alignment work, mechanical stability**
  - **Space for the VTX: VTX group**
    - **Smaller Polar angle coverage (15 -> 22 degrees)**
    - **Service space: patch panels, cooling pipes, cables**
  - **Reliable LS2 beam optics design: optics group**
    - **BG estimation (need to control acceptable level): BG group**
    - **SR heating estimation : Vacuum group**
- **oDC specification(gas and cell design) and plan**
- **iTT design and rough sketch of the integration plan**

backup

# Another idea

- Updating current CDC-> oDC+iTT
  - Removing small cell chamber at clean booth
  - Installing iTT
- Pros and Cons
  - Small area coverage of iTT
  - No chance to modify cell design on oDC
  - iTT structure need to be prepared in LS2
    - Delaying delivery could be the critical issue on the LS2 project

Listing remaining tasks/issues  
before finalizing IR design

Subject	Parts item/ study subject	Status and plan
IP beam pipe	Draft design with 16mm(dia.)	Yes
	Production procedure	The same as VXD
	FEM analysis	OK (can adopt VXD case)
	SR control (heating and BG hits on the VTX)	Need to check after Bellows pipe design
	Vertex resolution issue	Need further check
	Cooling for the hot spot area	New heatsink design is ready
	iVTX mount block	Design is agreed with QMUL
	Bracket for Diamond sensors	Location is the same as VXD

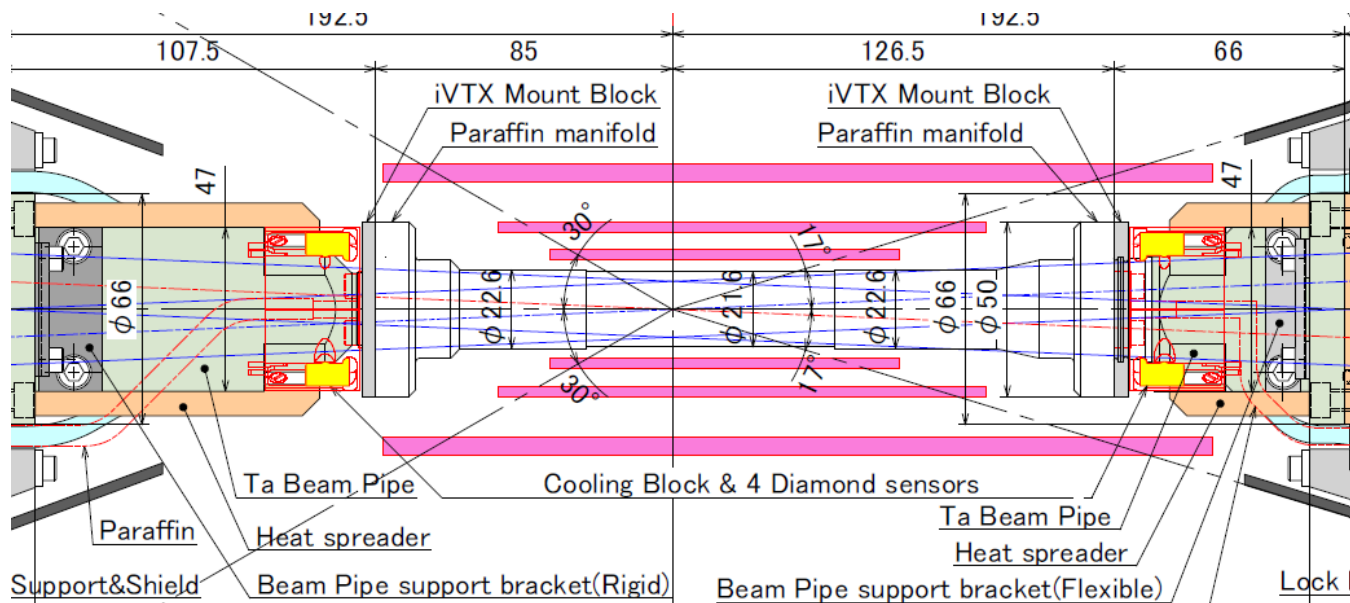

Subject	Parts item/ study subject	Status and plan
VTX mechanic parts	End-flange(AL)	(iteration btw. oVTX-KEK)
	CFRP support cone(oVTX)	(iteration btw. oVTX-KEK)
	Endring (SUS/AL?)	(ongoing : oVTX)
	Heavy metal shields	Draft design is ready.
	IP beam pipe brackets	Draft design is ready
	FEM analysis	OK(can adopt VXD case)
	Installation ring (AL)	Same as VXD design
	Integration procedure and tools	Will follow the VXD case but no rotation for iVTX
	Installation method (also brackets) and IP alignment method	Same as VXD case
	Service space for each sensors	On going business

Detail of each component (i.e. iVTX or oVTX) is not included

Subject	Parts item/ study subject	Status and plan
Beam pipe integration at IR (IP beam pipe + bellows pipe + QCS beam pipe)	IP beam Pipe(also bellows) diameter	16mm diameter is maximum size by taking into account of the vacuum connection at QCS head position.
	QCS beam pipe	Racetrack shape at QC1 and Tantalum can be used to mitigate BG loss (under discussion but likely) Integration method of QCS pipe with cryostat is agreed
	Bellows pipe	Mock test is scheduled in 2025 JFY. Full draft design will be in 2026JFY.
	BPM (QC1)	Options are prepared
	RVC	First mock test is done(FWD). Full size mock is on preparation. BWD RVC design should be ready. Emergency extraction is not discussed yet.
	SR estimation	Detailed check(hot spot check) is mandatory after the magnet allocation and beam pipe design is implemented in BASF2

Detail subjects of each component (i.e. QC1 magnet and it's cooling) is not included

Subject	Parts item/ study subject	Status and plan
Impact on the physics performances	oVTX polar angle acceptance (17-> 22° )	Ongoing (oVTX design)
	Vertex resolution degradation	On going (IP pipe design)
	CDC performance degradation by EM shower particles caused at VTX mount material	Not checked yet

# Reinforcement to stabilize Belle detector

Yamaoka

## 現状 (ISO3010)

➔ These are unacceptable deformations due to weak Belle stage.

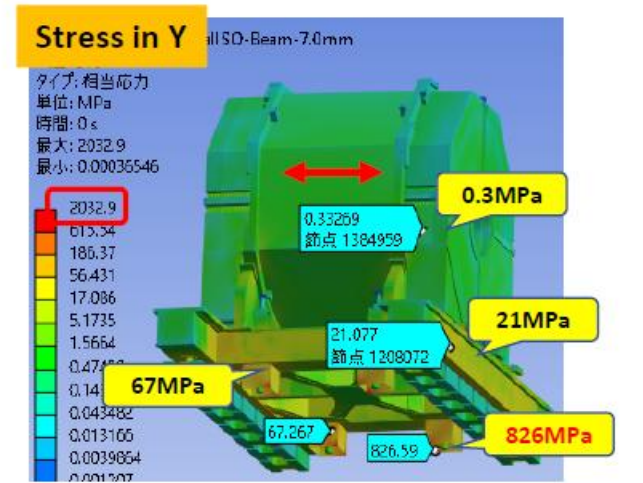
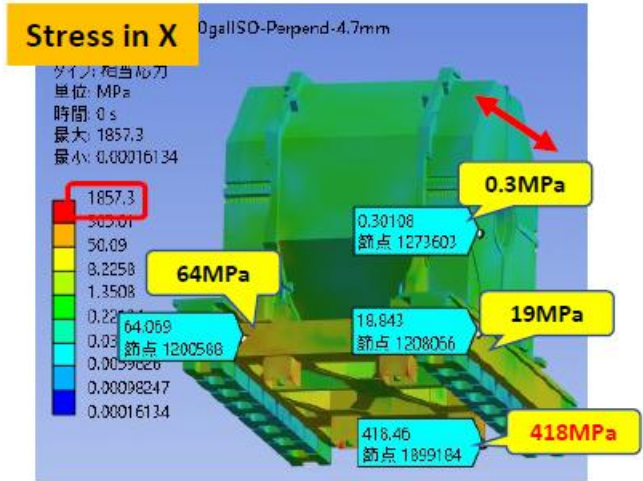

	X (Perpend.)	Y (Beam)
Resonance (Hz)	3.6	4.2
Rel disp. (mm)	4.6	6.7
Stress (MPa)	1857	2031 ➔ N.G.

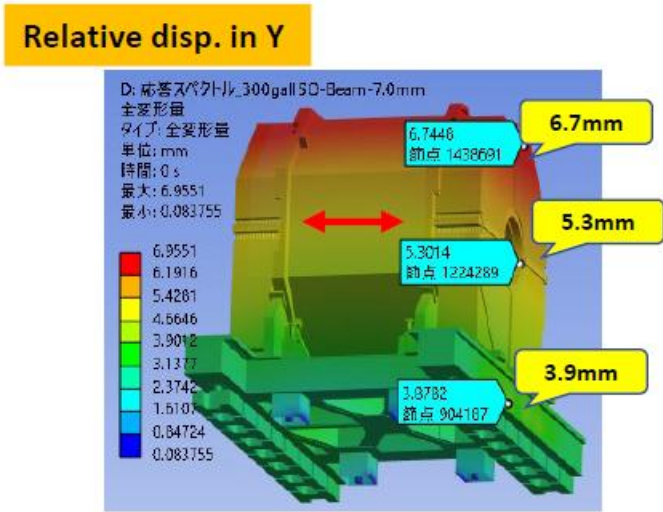
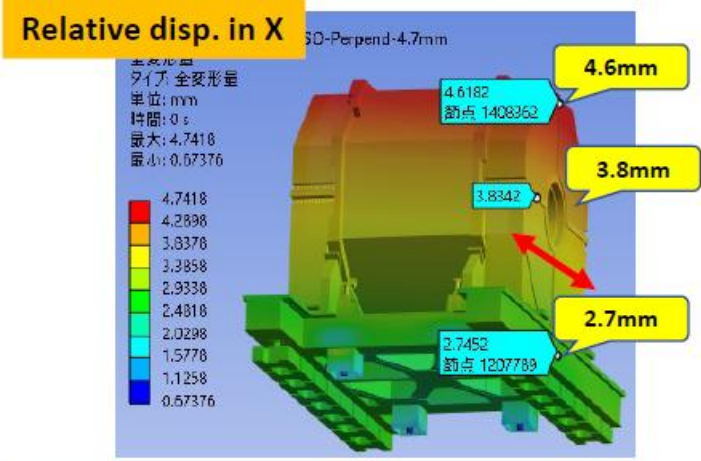

➔ **Conclusion: N.G.**  
➔ **Needs reinforcement!**

# RVC-mockup2 → RVC-mockup2-Plus

## [ RVC Capを作り替える前の改造案 ]

Φ8穴をBeam Pipeの中心にするとLock Flange側の穴に当たるので、穴の中心を1mmずらす

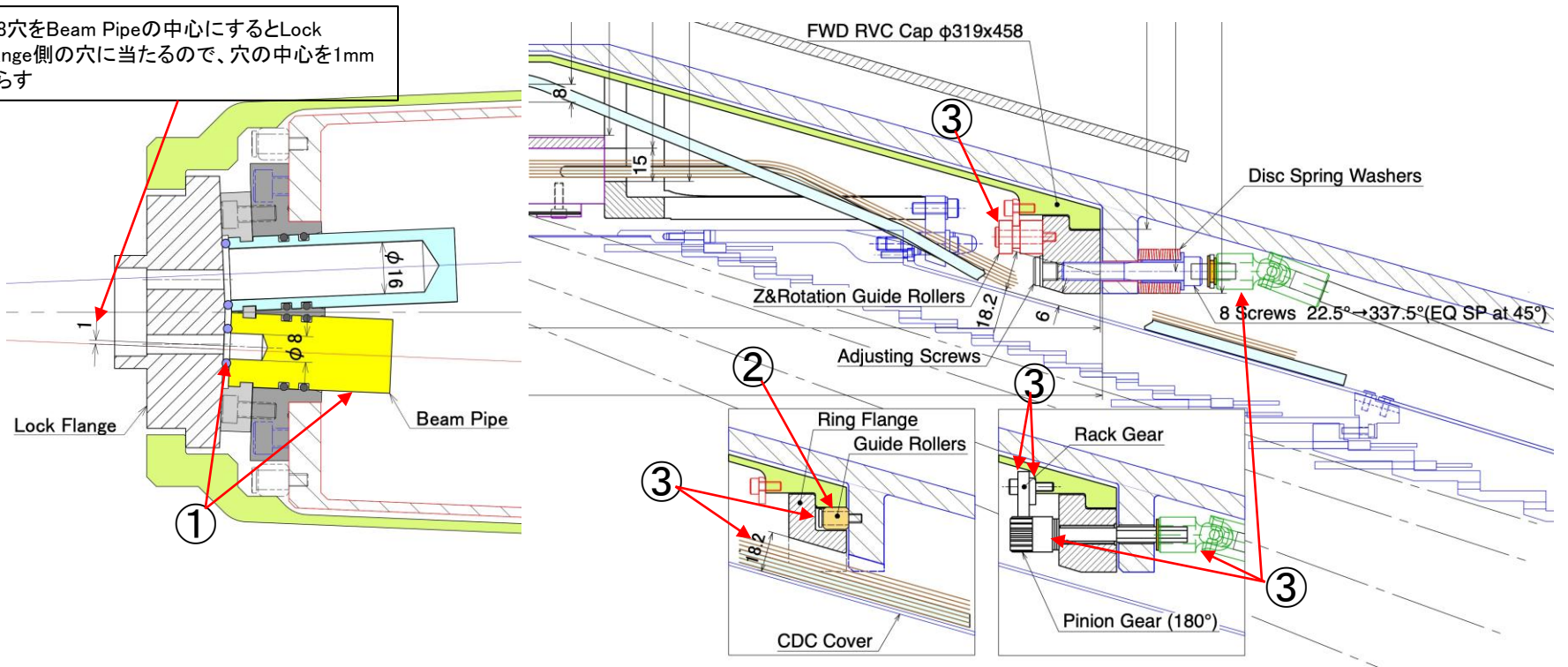

# BWD region cabling exercise – D = 7 mm

## BWD Excercise with n-1 cables

## BWD Excercise with n cables

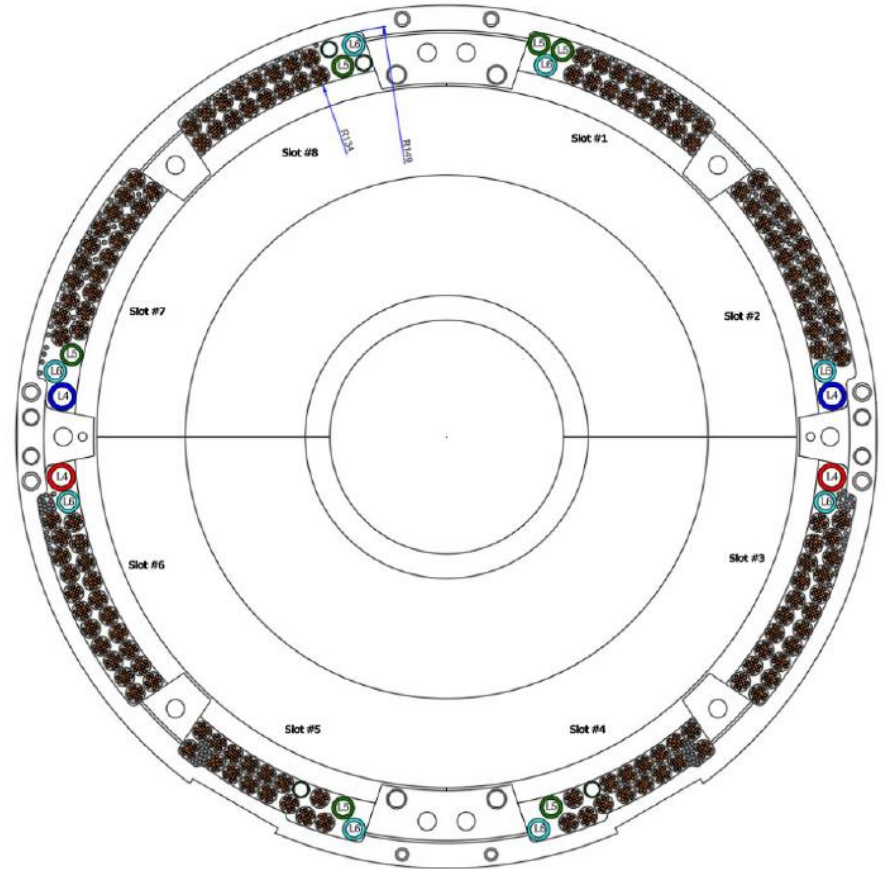
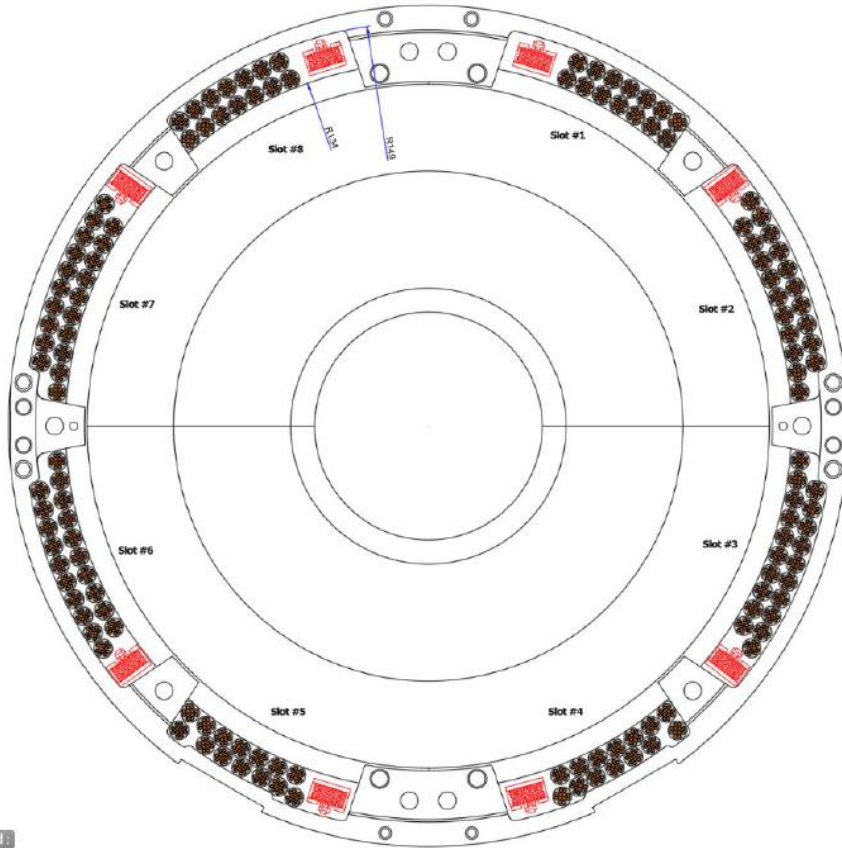

# FWD region cabling exercise – D = 7 mm

## FWD Excercise with n-1 cables

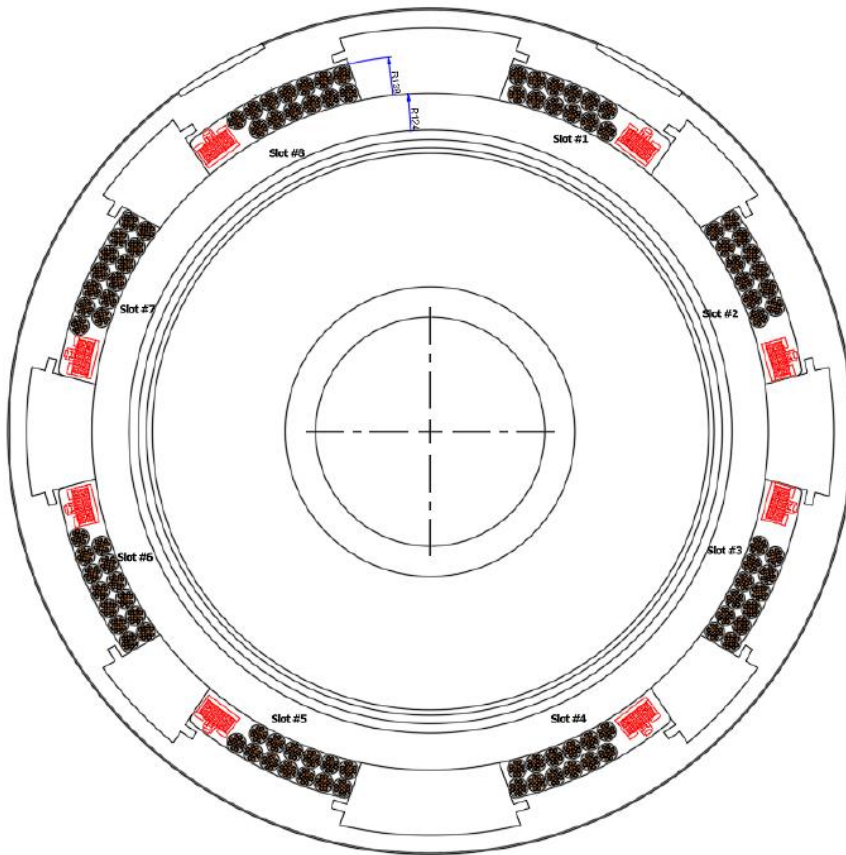

## FWD Excercise with n cables

